

2021

ABRITES Diagnostics for Renault/Dacia



# ABRITES DIAGNOSTICS FOR RENAULT/ DACIA

**User manual**  
version 2.7



## Important notes

---

The Abrites software and hardware products are developed, designed and manufactured by Abrites Ltd. During the production process we comply to all safety and quality regulations and standards, aiming at highest production quality. The Abrites hardware and software products are designed to build a coherent ecosystem, which effectively solves a wide range of vehicle-related tasks, such as:

- Diagnostic scanning;
- Key programming;
- Module replacement,
- ECU programming;
- Configuration and coding.

All software and hardware products by Abrites Ltd. are copyrighted. Permission is granted to copy Abrites software files for your own back-up purposes only. Should you wish to copy this manual or parts of it, you are granted permission only in case it is used with Abrites products, has "Abrites Ltd." written on all copies, and is used for actions that comply to respective local law and regulations.

## Warranty

---

You, as a purchaser of Abrites hardware products, are entitled of a two-year warranty. If the hardware product you have purchased has been properly connected, and used according to its respective instructions, it should function correctly. In case the product does not function as expected, you are able to claim warranty within the stated terms. Abrites Ltd. is entitled to require evidence of the defect or malfunction, upon which the decision to repair or substitute the product shall be made.

There are certain conditions, upon which the warranty cannot be applied. The warranty shall not apply to damages and defects caused by natural disaster, misuse, improper use, unusual use, negligence, failure to observe the instructions for use issued by Abrites, modifications of the device, repair works performed by unauthorized persons. For example, when the damage of the hardware has occurred due to incompatible electricity supply, mechanical or water damage, as well as fire, flood or thunder storm, the warranty does not apply.

Each warranty claim is inspected individually by our team and the decision is based upon thorough case consideration.

Read the full hardware warranty terms on our [website](#).

## Copyright information

---

### Copyright:

- All material herein is Copyrighted ©2005-2021 Abrites, Ltd.
- Abrites software, hardware, and firmware are also copyrighted
- Users are given permission to copy any part of this manual provided that the copy is used with Abrites products and the “Copyright © Abrites, Ltd.” statement remains on all copies
- “Abrites” as used in this manual synonymous with “Abrites, Ltd.” And all it’s affiliates
- The “Abrites” logo is a registered trademark of Abrites, Ltd.

### Notices:

- The information contained in this document is subject to change without prior notice. Abrites shall not be held liable for technical/editorial errors, or omissions herein.
- Warranties for Abrites products and services are set forth in the express written warranty statements accompanying the product. Nothing herein should be construed as constituting any additional warranty.
- Abrites assumes no responsibility for any damage resulting from the use, misuse, or negligent use of the hardware or any software application.

## Safety information

---

The Abrites products are to be used by trained and experienced users in diagnostics and reprogramming of vehicles and equipment. The user is assumed to have a good understanding of vehicle electronic systems, as well as potential hazards while working around vehicles. There are numerous safety situations that cannot be foreseen, thus we recommend that the user read and follow all safety messages in the available manual, on all equipment they use, including vehicle manuals, as well as internal shop documents and operating procedures.

Some important points:

Block all wheels of the vehicle when testing. Be cautious when working around electricity.

- Do not ignore the risk of shock from vehicle and building-level voltages.
- Do not smoke, or allow sparks/flame near any part of the vehicle fuel system or batteries.
- Always work in an adequately ventilated area, vehicle exhaust fumes should be directed towards the exit of the shop.
- Do not use this product where fuel, fuel vapours, or other combustibles could ignite.

In case any technical difficulties occur, please contact the

**Abrites Support Team by email at [support@abrites.com](mailto:support@abrites.com).**

# Table of contents

1. Introduction .....	6
2. Getting Started .....	7
3. Standard Diagnostics .....	8
3.1 Module Identification .....	8
3.2 Reading and clearing Diagnostic Trouble Codes (DTC) .....	9
3.3 Actual Values .....	10
3.4 Actuator Tests .....	11
4. Advanced Diagnostics .....	12
4.1 PIN code reading and key learning .....	12
4.1.1 Common procedure .....	13
4.1.2 X95 based cars .....	15
4.1.3 X95 based cars with updated software .....	16
4.1.4 Using “Abrites key” cards .....	17
4.2 Dump Tool .....	24
4.3 Change ID .....	24
4.4 PIN Calculator .....	25
4.5 Clio PIN by dump .....	25
4.6 Cluster calibration .....	25
4.7 ECU configuration data, flash and IMMO data reading and updating ...	27
4.7.1 EDC15C3 .....	29
4.7.2 EDC15C13 .....	30
4.7.3 SID301 .....	30
4.7.4 SIRIUS 32 .....	31
4.7.5 SAFIR/SAFIR2/SFR200 using 35 or 55 pin connector .....	32



# Table of contents

4.7.6 SIM32 .....	34
4.7.7 IAW 6R.20/6R.30 .....	34
4.7.8 EDC17 Boot mode reading .....	35
4.8 EDC 17 Specific functions .....	36
4.9 Renewal.....	39
4.10 Radio Code.....	43
5. Connecting ECUs on bench using ZN051 Distribution Box .....	44

## List of revisions

Date	Chapter	Description	Revision
11.11.2008		Release version of the document	1.0
18.03.2009		Update to V 1.1 of the software	1.1
17.06.2009		Update to V 2.0 of the software	1.2
20.01.2010		Update to V 2.3 of the software	1.3
31.05.2010		Update to V 2.6 of the software	1.4
28.07.2010		Update to V 2.8 of the software	1.5
02.11.2011		Update to V 5.0 of the software	2.0
11.10.2012		Update to V 5.2 of the software	2.1
30.11.2015		Total update; Abrites cards added, PROTAG programmer	2.2
31.03.2016		ECU update/ EDC17 boot and diagnostics	2.3
26.04.2016		Chapter 4.6 updated	2.4
01.11.2016		Updated pinouts	2.5
20.11.2016		Reading the CLIO IV/ Captur handsfree module	2.6
23.03.2017		Update to V 7.3 of the software - added unit Renewal and Radio Code	2.6
13.06.2018		Connecting ECUs on bench using ZN051 Distribution Box	2.7
21.06.2019		Updated mileage calibration procedure - re-enabling sync info added	2.7

# 1. Introduction

---

The "Abrites Diagnostics for Renault/Dacia" is a personal electronic device and online server based diagnostic software for Renault/Dacia vehicles. With the help of this software you can perform complete diagnostic operations of all vehicles produced by the brand. For proper operation of your diagnostic software you will need a corresponding interface for connection between your PC and vehicle named "AVDI". The usage of the software requires the device it is installed on (i.e. personal computer) to be connected to the Internet. AVDI is an interface produced by Abrites Ltd. intended to act as an interface between the PC and the electronic control units within the vehicles.

Your AVDI should be used with ABRITES software produced by Abrites Ltd. ABRITES is a trade mark of Abrites Ltd.

## 2. Getting Started

The Abrates diagnostics for Renault/Dacia is installed together with the software applications as a part of the installation provided to the user with the e-mails sent.

You can start the Abrates diagnostics for Renault/Dacia from the Quick start icon, installed on your desktop upon installation of the Abrates diagnostic suite. You will be able to start it by clicking on the brand logo. When the software opens the user will see the following screen:

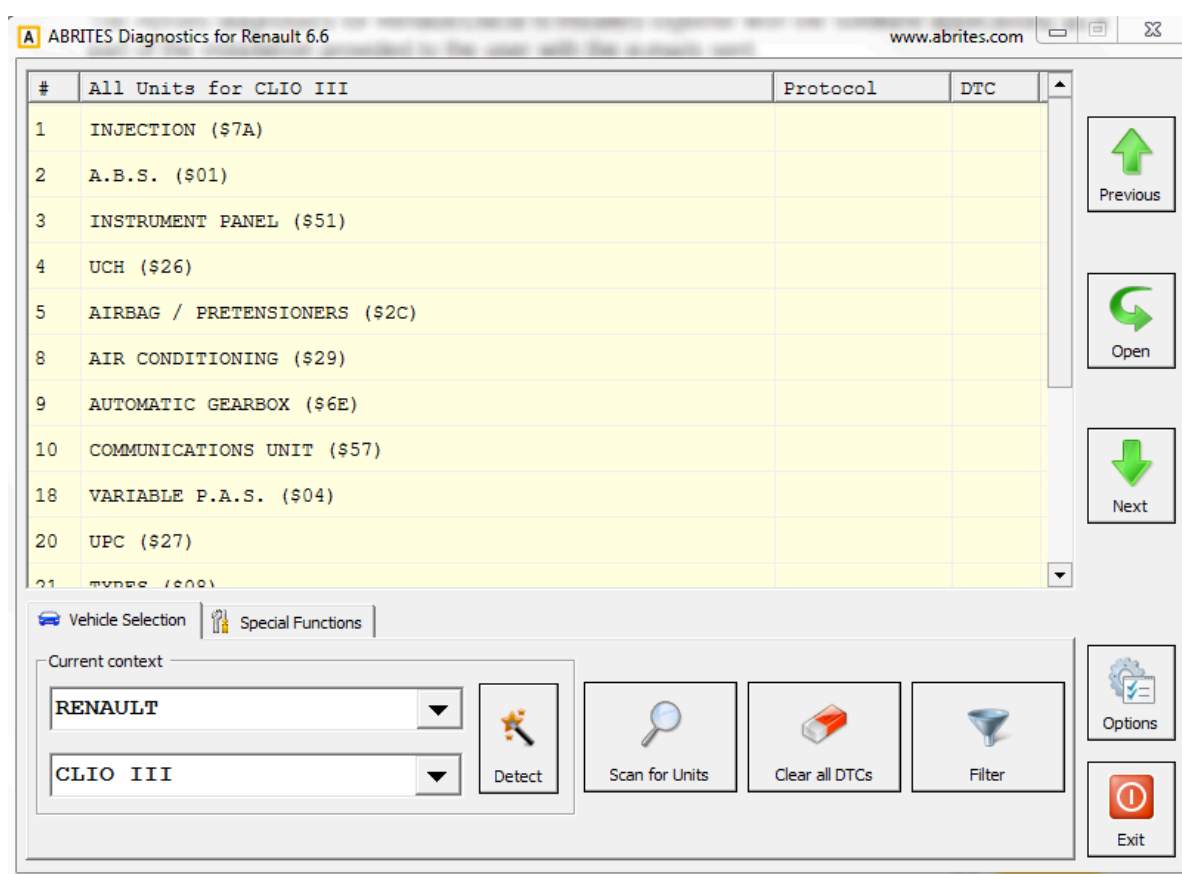

In this main screen the user can select the model of the vehicle and proceed to diagnostics or click the "Detect" button in order for the Abrates diagnostics for Renault/Dacia to automatically detect the vehicle.

## 3. Standard Diagnostics

The Abrates diagnostics for Renault/Dacia provides a multitude of options in terms of standard diagnostics. It can assist the user to read and clear diagnostic trouble codes (DTC), perform identification on the electronic control modules installed in the vehicles produced by Renault and Dacia, show the actual values of the vehicles in real time in a list form as well as a graph and also perform actuator testing in order to determine the cause of issues within the vehicles.

### 3.1 Module Identification

Once the software identifies the vehicle make and model the user will see the list of modules installed in the particular vehicle. When they choose a module and click on it the following screen will be displayed:

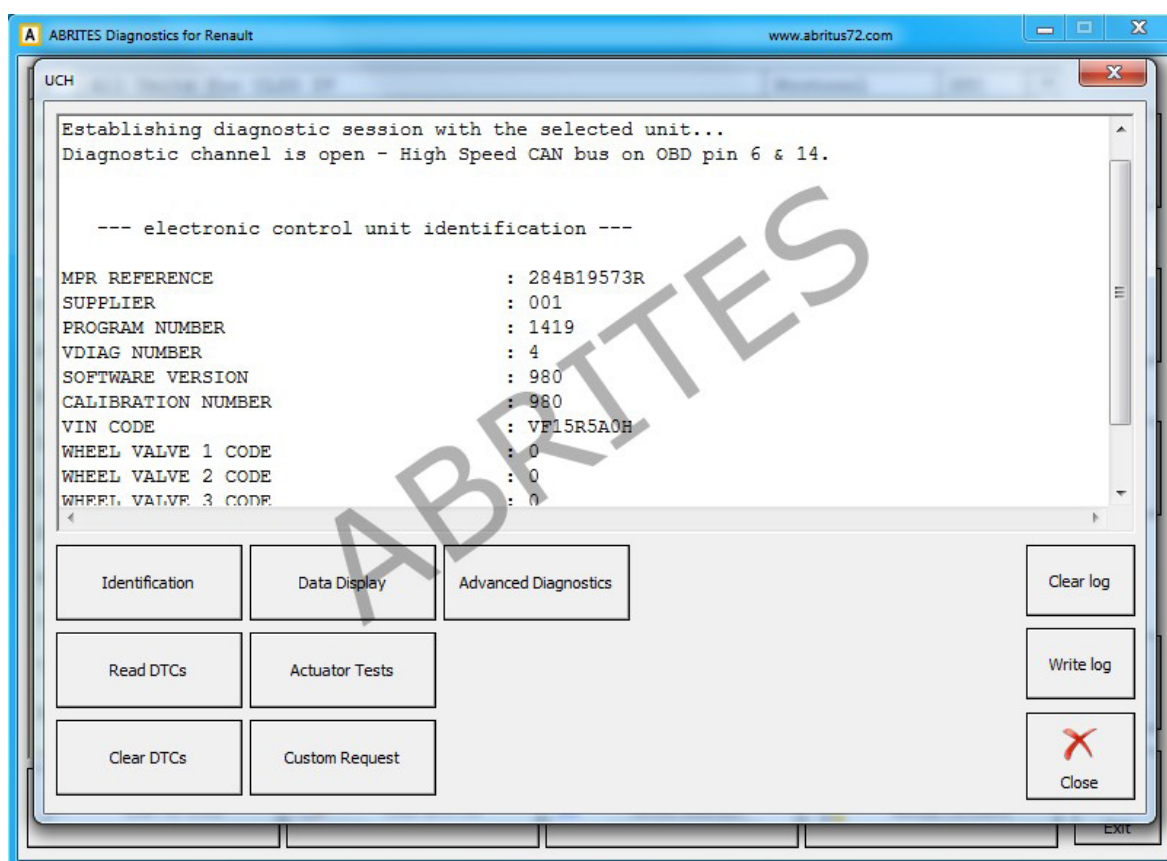

Using the "Identification" button the user will have all the available information for the module. This includes part number, supplier, programming number, VIN, as well as many other details. This will help in the cases where a replacement unit is needed.

### 3.2 Reading and clearing Diagnostic Trouble Codes (DTC)

Diagnostic Trouble Codes are one of the first signs of issues with a vehicle. Abrates diagnostics for Renault/Dacia provides reading and clearing of these codes as well as full information about the codes themselves. Once the module that is diagnosed is found (after scanning for trouble codes from the main screen the DTCs are displayed in a list next to the electronic modules) the user can enter the module and select the “Read DTCs” button.

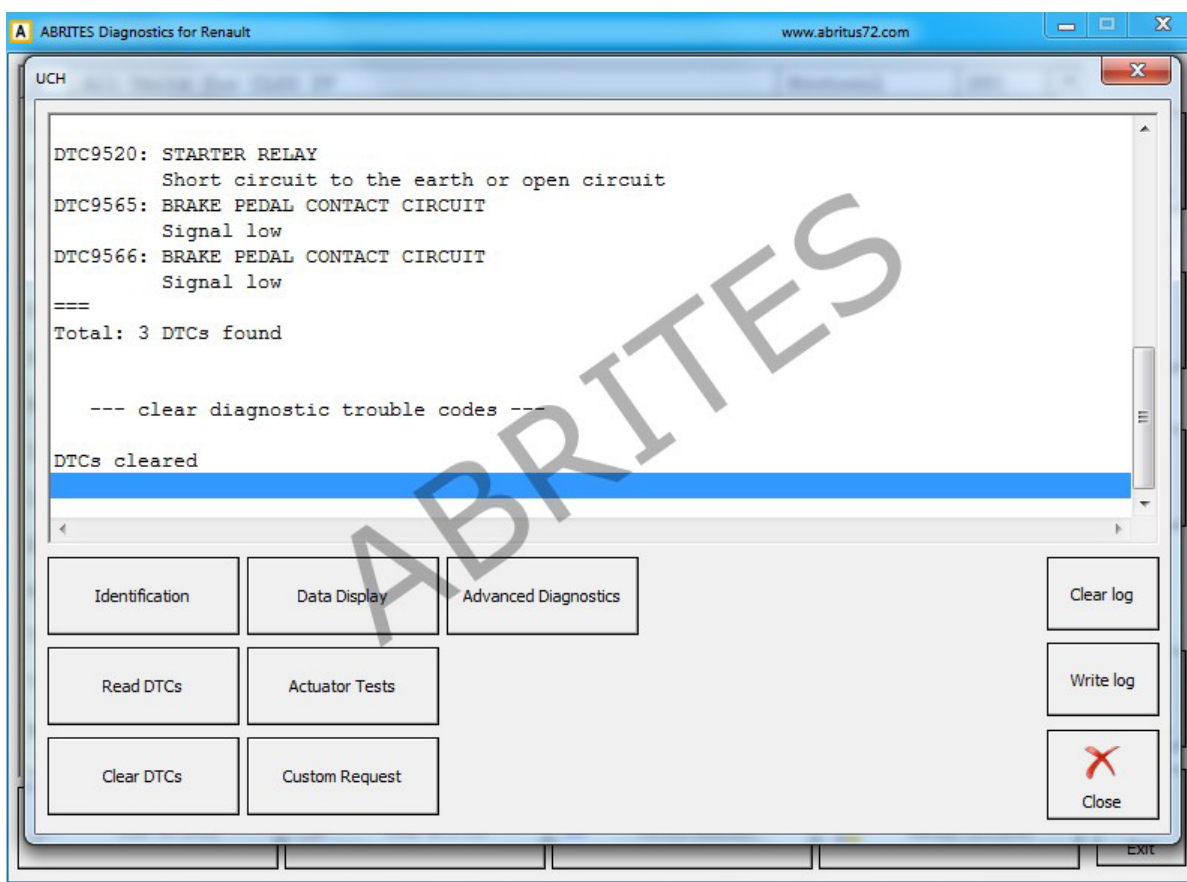

A description of the trouble code is provided. It contains the description of the DTC (one or more), the car's code for it as well as the total amount of the discovered trouble codes. Once the user is done with the analysis of the present codes and the repair of the fault itself they can proceed to clicking the “Clear DTCs” button which will remove the code from the electronic unit's memory.

### 3.3 Actual Values

Actual values are an inseparable part of the detailed diagnostics of a vehicle. They are used to monitor and observe the details of operation of the vehicles's components in real time and can allow the user to make adjustments to the vehicle and immediately see their effect. The actual values can be viewed using the "Data display button". They can be monitored as a list or in graph form:

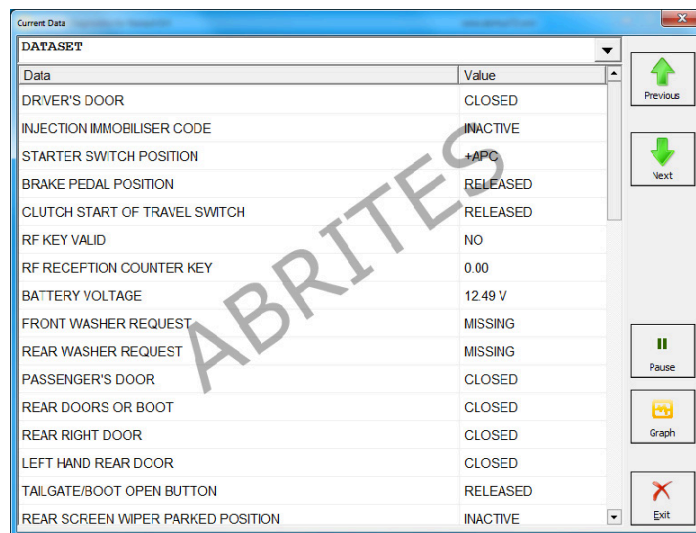

Data	Value
DRIVER'S DOOR	CLOSED
INJECTION IMMOBILISER CODE	INACTIVE
STARTER SWITCH POSITION	+APC
BRAKE PEDAL POSITION	RELEASED
CLUTCH START OF TRAVEL SWITCH	RELEASED
RF KEY VALID	NO
RF RECEPTION COUNTER KEY	0.00
BATTERY VOLTAGE	12.49 V
FRONT WASHER REQUEST	MISSING
REAR WASHER REQUEST	MISSING
PASSENGER'S DOOR	CLOSED
REAR DOORS OR BOOT	CLOSED
REAR RIGHT DOOR	CLOSED
LEFT HAND REAR DOOR	CLOSED
TAILGATE/BOOT OPEN BUTTON	RELEASED
REAR SCREEN WIPER PARKED POSITION	INACTIVE

In the list view the options are stacked and their status value is displayed on the right hand side of the screen.

Using this view many separate sources can be viewed simultaneously. The user can choose to freeze the live data reading in order to observe and analyze them at a particular point.

The live values can also be displayed in a graph. This graph can be opened by selecting the "Graph" button. It can be recorded, saved and played for further analysis. The user can zoom the graph for additional details or to see it in a larger scale so that the vehicle's behaviour can be thoroughly analyzed:

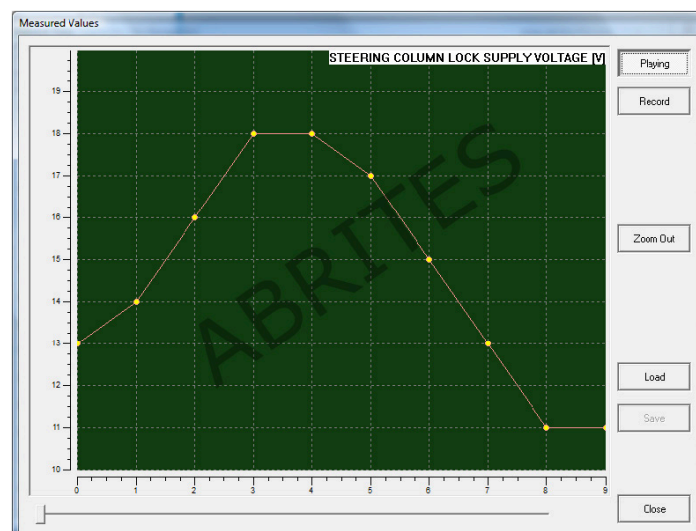





## 4. Advanced Diagnostics

Abrites diagnostics for Renault/Dacia provides the user with advanced diagnostic functions in the form of special functions. These functions can be used in the cases where a vehicle is in need of special operations such as key learning and PIN code reading ( used mostly by automotive locksmiths, but applicable in repair shops too), module ID replacement (valid in the cases where an electronic module requires replacement), reading mileage and calibration (once again – extremely valuable when replacing a module), Airbag memory manager (used often in the field of damage repair workshops).

### 4.1 PIN code reading and key learning

In order to open the key learning functions of the Abrites diagnostics for Renault/Dacia the application should be started. On the main screen the user should select the “Special functions” menu:

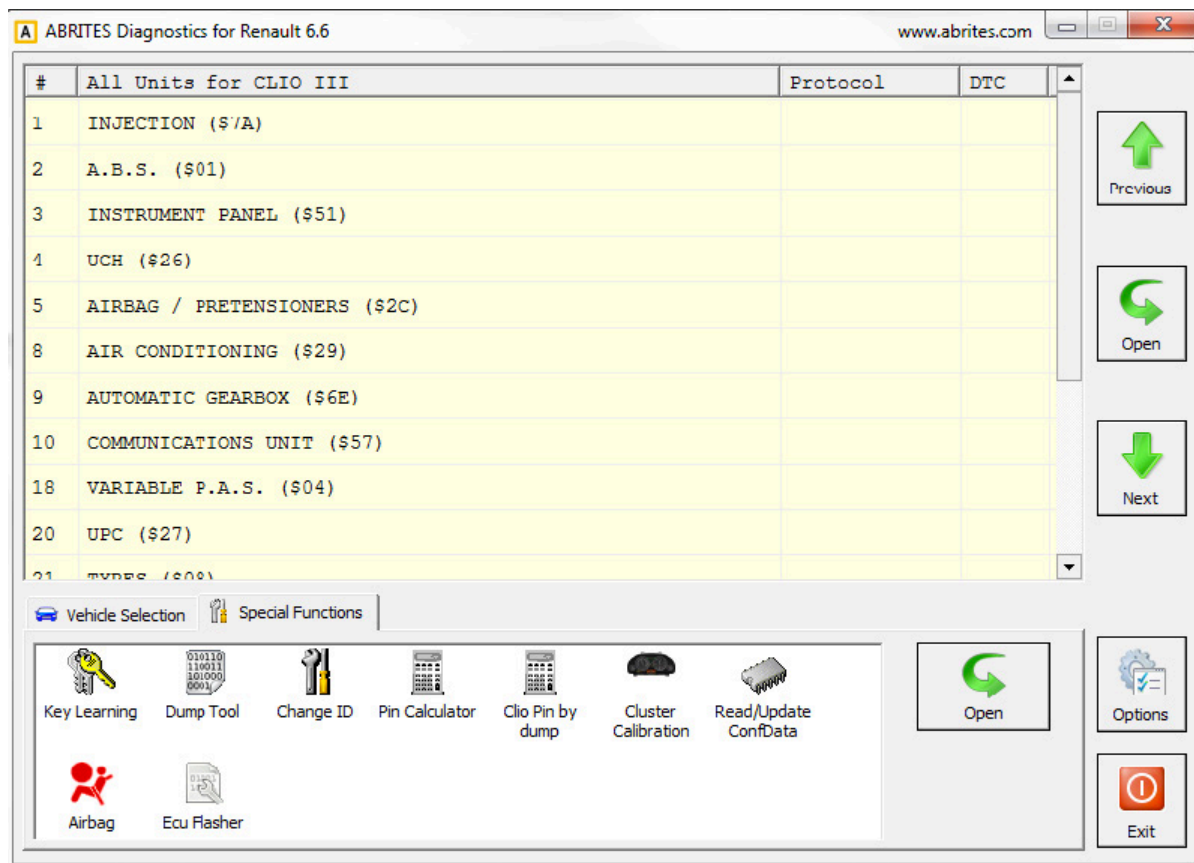

Once in the main screen the user will see the special functions list. Please note that not all special functions may be included in the basic software and they must be purchased in order to be used.

### 4.1.1 Common procedure

There is function for auto-detection of the vehicle model. Nevertheless if you don't succeed to learn the key using the auto-detection, please try to make it by selection the model manually from the drop down list of supported models:

Clio II Ph2/3	X65	2002-2006
Master Ph2	X70	2002-2006
Master Ph3	X70	2007+
Master III	X62	2010+
Megane II	X84	2003-2006
Megane II Ph2	X84	2007+
Megane III	X95	2009+
Megane III RS	X95	2009+
Modus	X77	2004+

When this function is opened, the “ABRITES Diagnostics for Renault/Dacia” opens the following dialog:

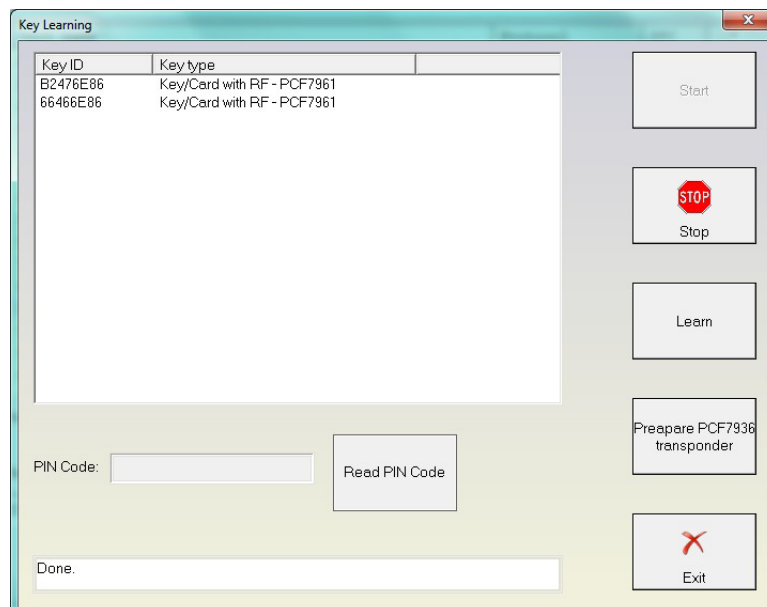

When you press the “Start” button then application connects to the immobilizer and reads the keys which are currently accepted from the car. If you want to learn a key/card, then you need to press the “Learn” button and you’ve to specify how many keys/cards you want to learn.

After that you should follow the instructions.

Normally the procedure goes in that way:

1. When pressing the start button the application is connecting to the immobilizer and displaying the present keys/cards. In most cases it is not required that the car is on ignition, for some cars the immobilizer is awake directly from the diagnostic. But on some cars it may happened that the ignition is given when connecting to the device.
2. After pressing the "Learn" button and specifying the number of keys you will be invited to remove the key/card from the ignition. Please be sure that the key/cards is really removed after this. Otherwise immobilizer will reject the key-learning procedure.
3. After that you will be invited to insert each next key/card and give the ignition ON. For each key there are several seconds required until the immobilizer recognize the key/card.

**NOTE:** For some models there are two ways to learn keys/cards – regular procedure or using direct writing to the EEPROM memory. For Clio III Direct, Modus Direct and Traffic III Direct the keys are put into the programmer, not into the ignition. When putting the key into the programmer please be sure that it is correct placed as shown in the pictures below:



4. Step "3" is repeated for each key you want to learn.
5. After inserting all keys which have to be learned you will be asked whether you want to store the result or to reject the whole procedure (useful if you made a mistake during the key-learning procedure like forgot to put a key).

If you do not have an original key for the model, you can use PCF7936 transponder to make a key for the car. Please note that PCF7936 might be used only on cars with key, not on cars with cards! Also if you learn PCF7936 transponder there will be no remote control for that key! So if you want to use such PCF7936 transponder, you should connect your programmer, put a factory new transponder inside and press the "Prepare PCF7936 transponder".

---

#### 4.1.2 X95 based cars

For X95 based cars (Megane III/ScenicIII/Fluence, etc) there is a difference in step “2” from the common procedure. The rule is that if you will learn a new (virgin) key/card, put the card in the ignition lock (without giving IGNITION ON), if you will learn an already pre-coded or working keys/cards - there should be no key/card in the ignition lock. Here are some examples:

- if you will learn a virgin card, put this card in the ignition lock. For example if car has two working cards, and you want to add one, you should specify 3 cards for the key count, put the virgin card in the ignition, then when invited to put first key/card – do nothing. Then when invited to put second and third key/card, put the original working keys into the ignition. If you want to add two virgin cards, you need to execute the whole procedure twice!
- if you will learn only cards which are working (e.g. car has three working cards, one of them is loosed and you want to relearn that only the other two cards continue to work), in that case no card should be on the ignition for this step.

NOTE: For Renault Fluence if you want to learn a virgin key, put it in the ignition lock (without giving ignition ON) and perform the procedure (this is the original procedure). If you’ve message “PIN code not accepted! Make sure ignition is OFF!” - then repeat the procedure from the beginning with the SAME VIRGIN KEY, and this time the key should be outside the ignition lock! (i.e. the exception here is that the virgin key is not in the ignition lock).

### 4.1.3 X95 based cars with updated software

Starting from about 2011 these cars have updated software in the immobilizer and it is no more possible to make them by OBDII. With ABRITES Diagnostics for Renault, it is possible to make cards for them, but you should first read them with the ABPROG. You can easily recognize these immobilizers since they are showing "09090909" for the existing key-IDs.

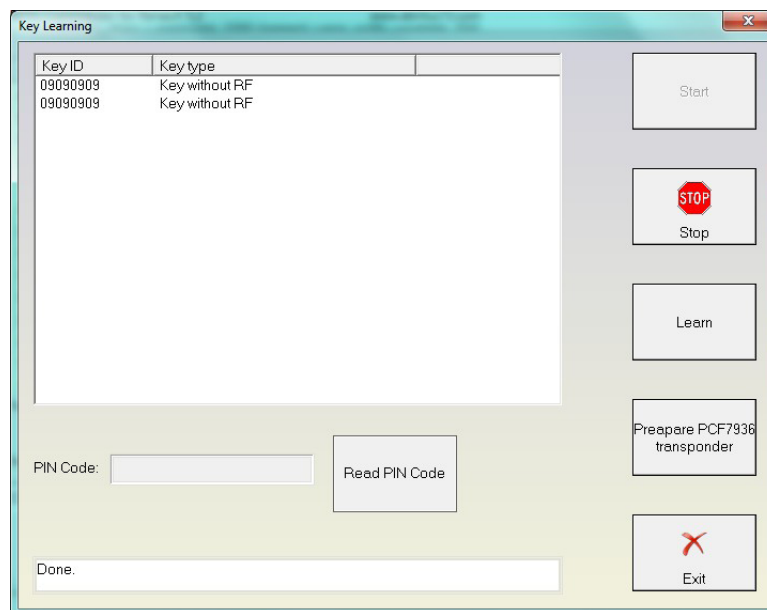

If you press "Learn" or "Read PIN Code" for such immobilizer, there will be a warning that first you need to read the immobilizer with the ABPROG. You should press here "Yes" after you already read the immobilizer dump.

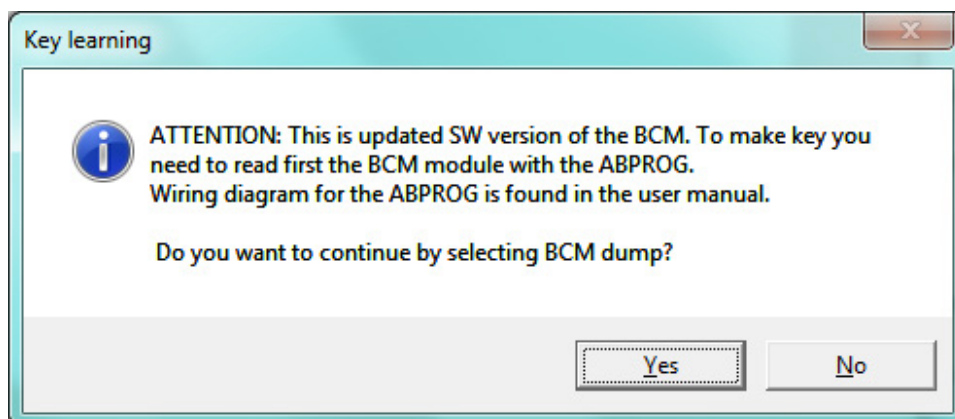

To read using Abprog please refer to the Abprog user manual.

#### 4.1.4 Using “Abrates key” cards

Vehicles like the Clio IV can use the key cards, produced by Abrites Ltd. These cards come prepared for the user and look like this:

*It is used together with the Abrites PROTAG programmer and can be purchased from [abrites.com](http://abrites.com) or our dealer network.*



The correct position of the card over the PROTAG programmer is shown below:





The procedure for “Abrates key” cards requires connection to the internet. The car will be autodetected:

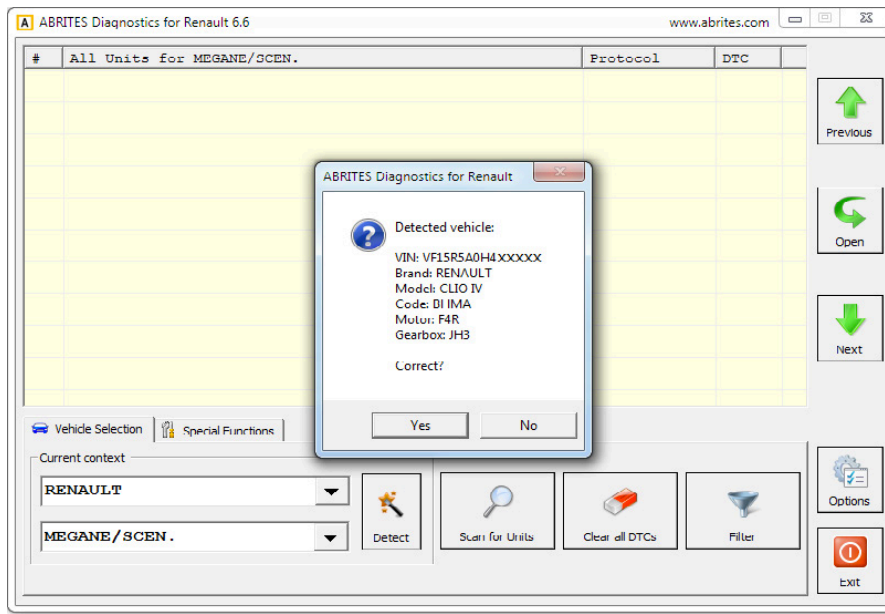

The Abrites diagnostics for Renault/Dacia will ask you to confirm whether or not the vehicle is correctly autodetected. You can confirm.

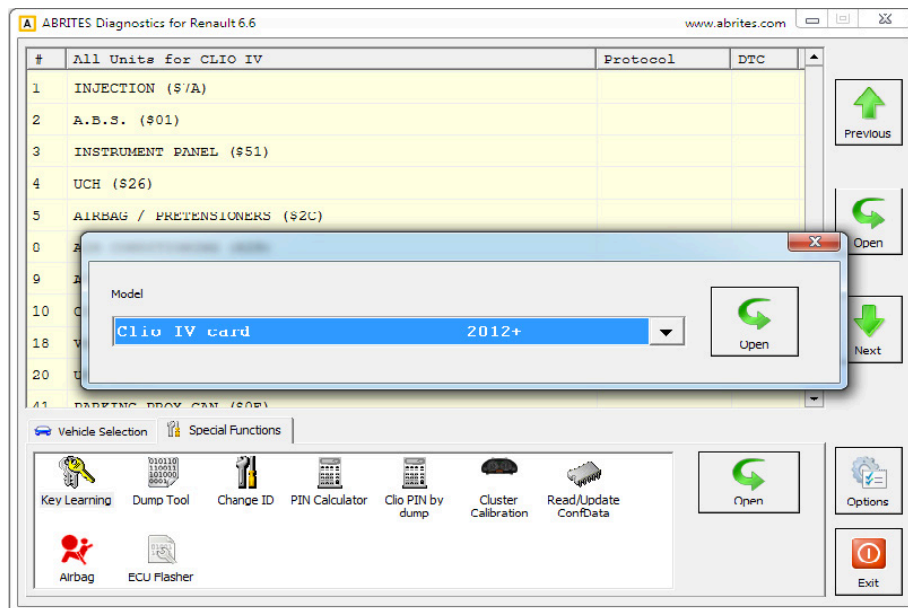

Press start and the software will ask you to input the number of keys to be programmed:

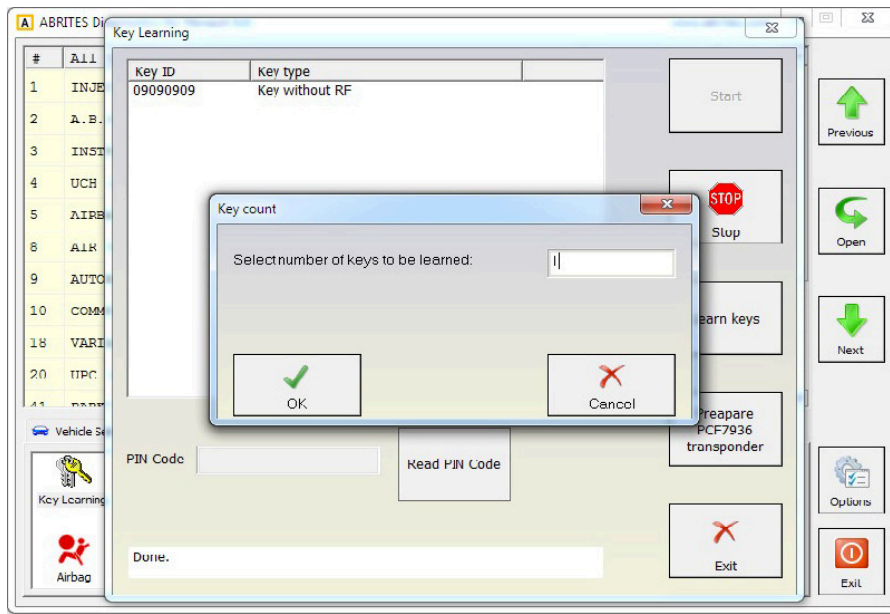

In this case we will be programming 1 key-card.

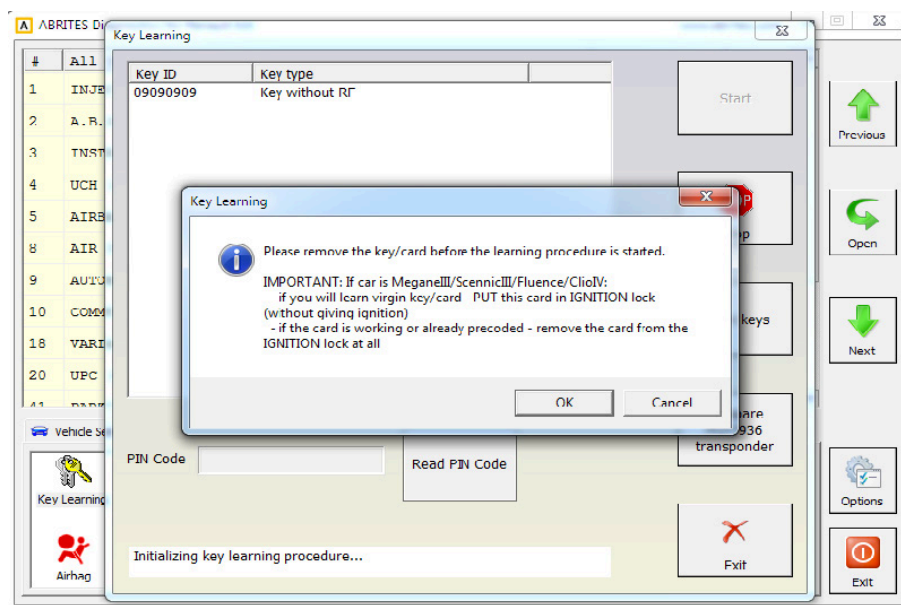

After following the instructions the Configuration data and PIN are being read:

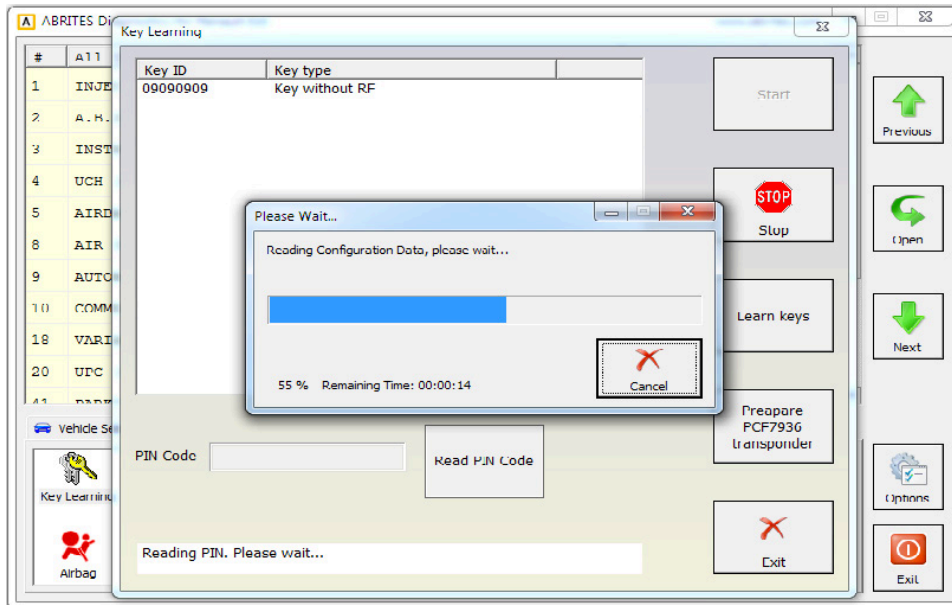

At this point the software will ask you if you are using an ABRITES key. Please confirm.

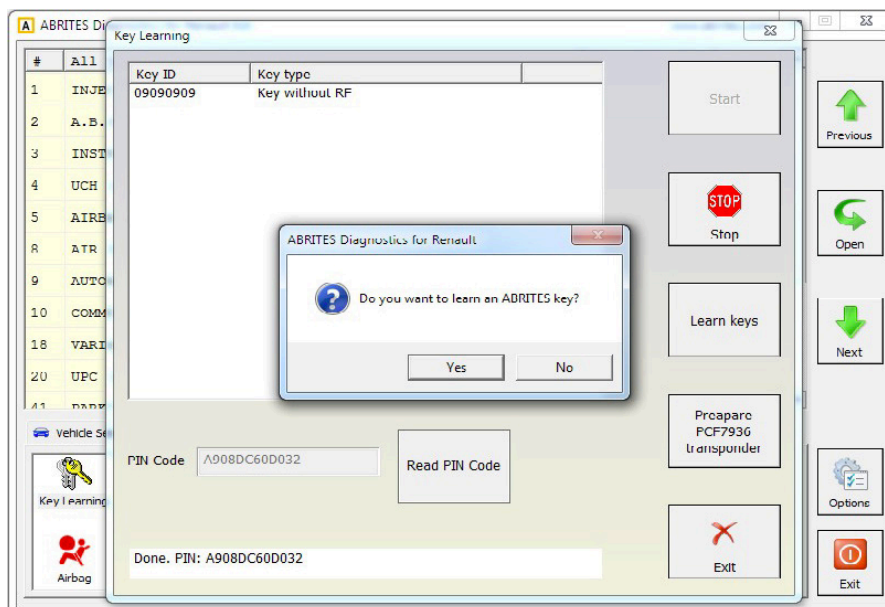

At this point you will be reminded to check the internet connection.

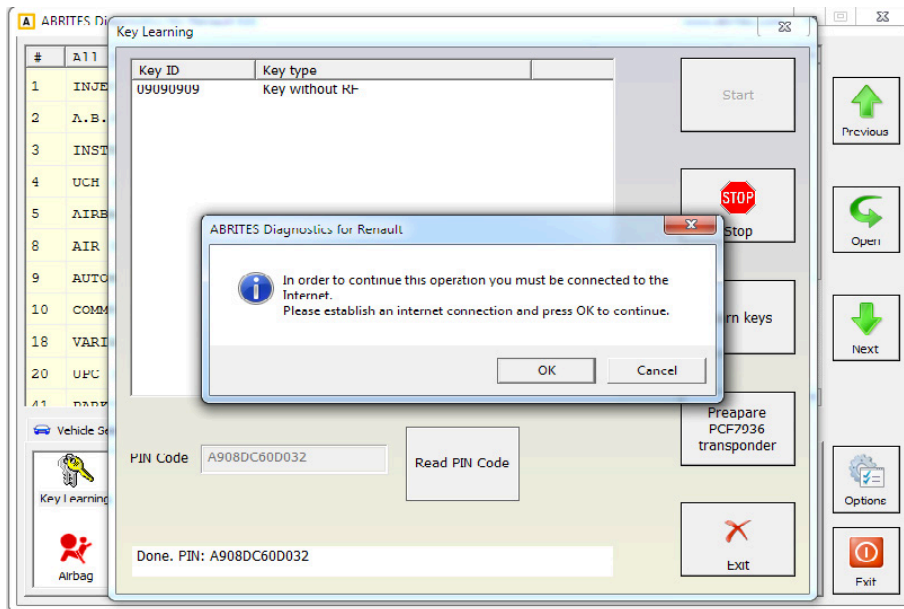

Then connect the PROTAG programmer:

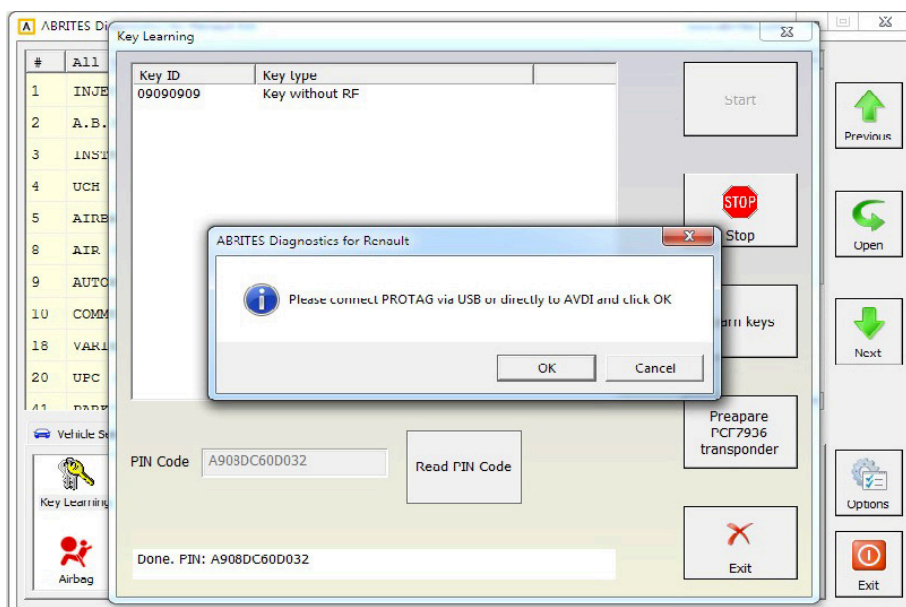

Then place the Abrites card over the Protag programmer as per the photo above and click “OK”

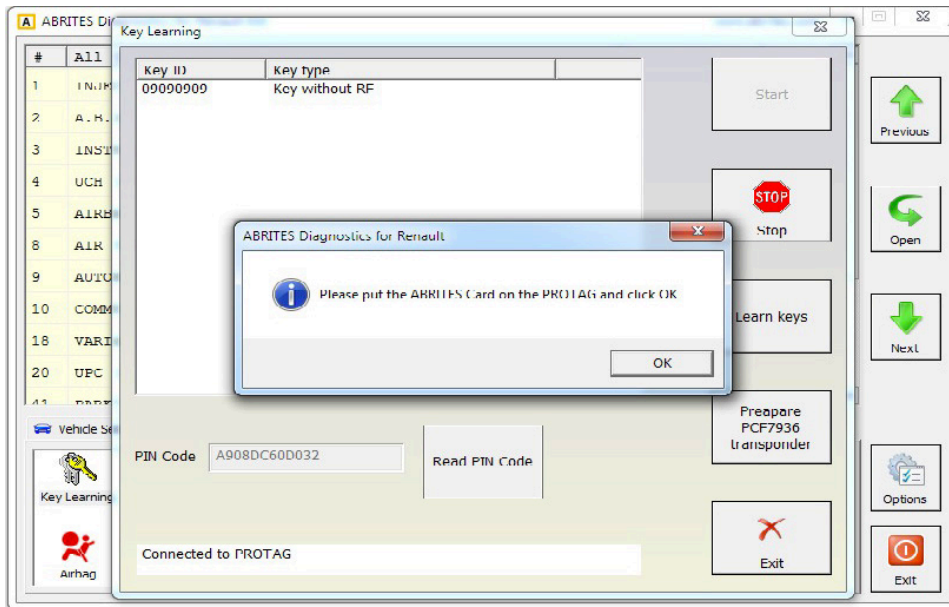

The Abrites card will be prepared:

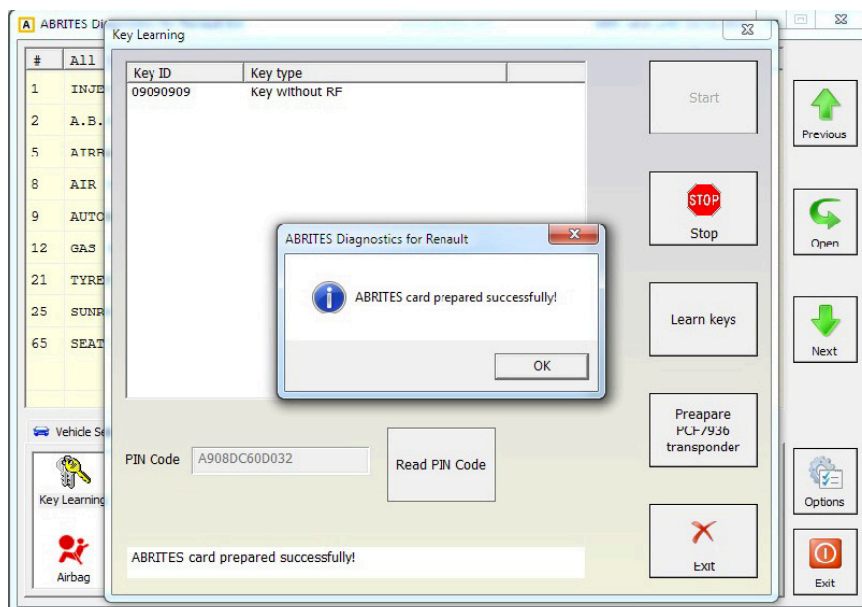

Continue by putting the card in the ignition and press OK

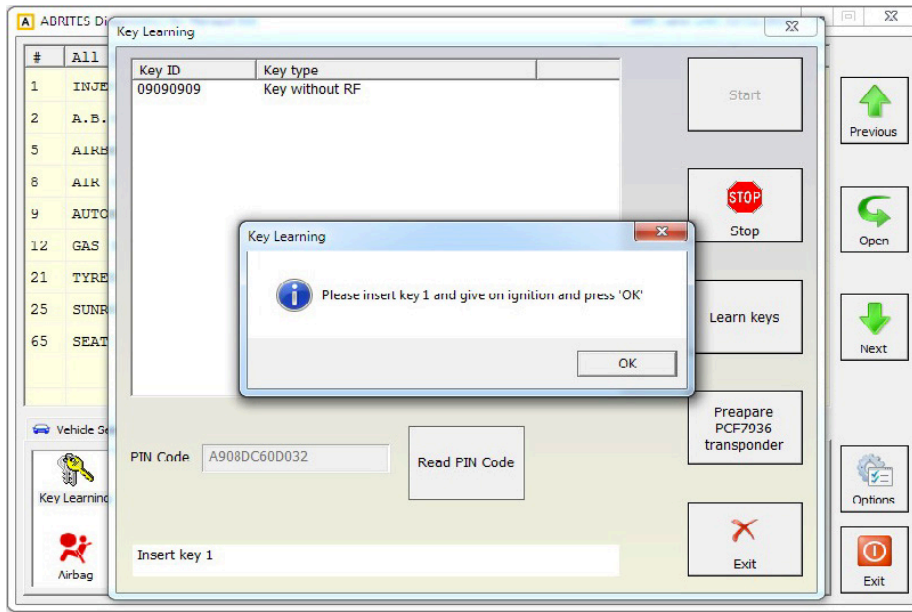

The software will then confirm by saying "Done" in the bottom left corner:

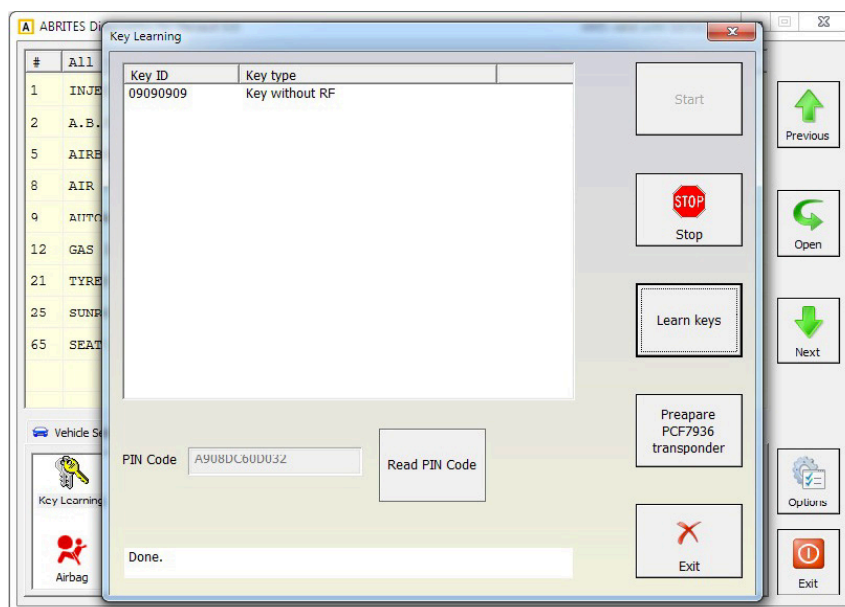

Please note that in case you have not used an Abrates card during the process the software will note this immediately.

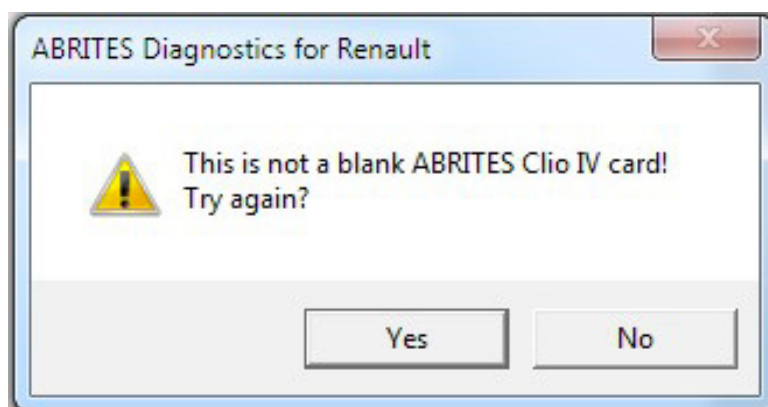

## 4.2 Dump Tool

The dump tool give to the user the ability to make modification in the dump files of different devices (e.g. airbags). But you will need to read EEPROM/flash with a programmer, and after modifications in the dump tool the resulting file has to be write back to the EEPROM/flash with a programmer.

## 4.3 Change ID

Calling this function will bring you a dialog, where all devices for the selected model are available.

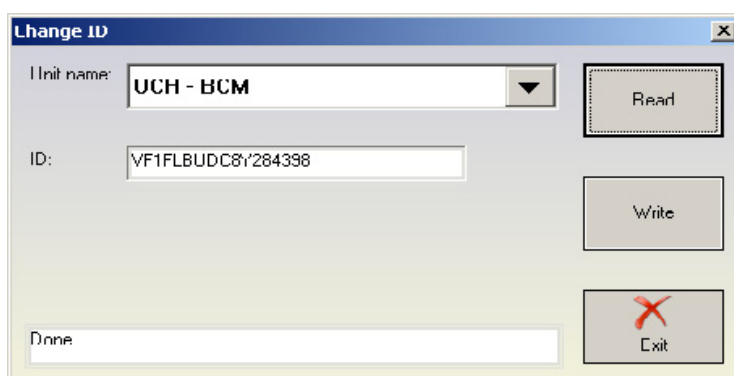

For each device you can try to read and change the Vehicle Identification Number. When changing this number there is also a checksum which is calculated automatically. Please note that in the most of the device there will be no such number present.



#### 4.4 PIN Calculator

This is a calculator which can evaluate the immobilizer security code from the vehicle model and the code written on the key itself (when you open the key). This calculator is used for cars with 4 digit PIN till 2001 year.

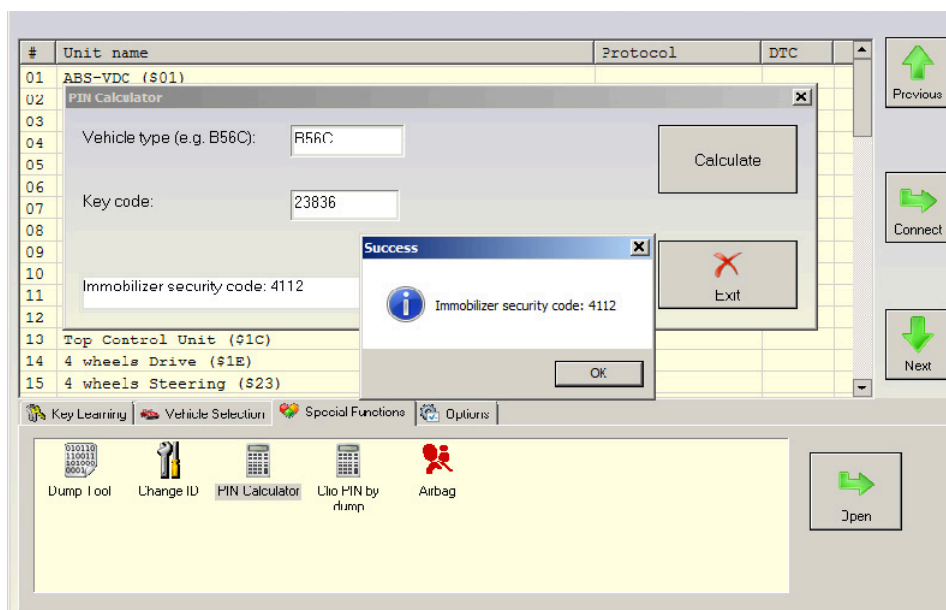

#### 4.5 Clio PIN by dump

This is a calculator for getting the Clio PIN code from the immobilizer dump. After starting this special function you will need to select the EEPROM dump file and after that you will get the security (PIN) code.

#### 4.6 Cluster calibration

This function allows the user to calibrate the mileage in all relevant modules. Please note that regarding the vehicle models that use ABS synchronization there is the added option to disable the sync. This special function also provides the option to read and write the EEPROM and flash so that in case of any issues during calibration or others you can repair the vehicle. The function provides the added option to disable the synchronization between the cluster and the ABS module - Ideal for replacing components containing the vehicle mileage. Once you replace the faulty mileage containing module you can set the value to the car's actual mileage with no more than a few clicks. Incrementing and decrementing is available in this option.

You can re-enable the synchronization easily by reflashing the cluster with its original file which you can find in the log files folder. It is automatically saved there before you start the synchronization disabling procedure.

In order to determine the mileage it has to be read:

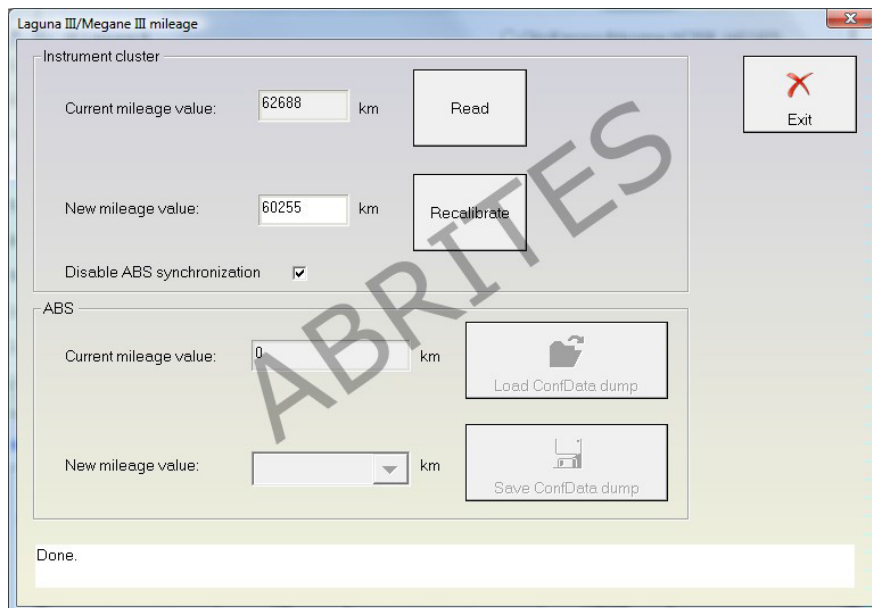

In some cases it is inevitable to disable the synchronisation between the ABS and cluster:

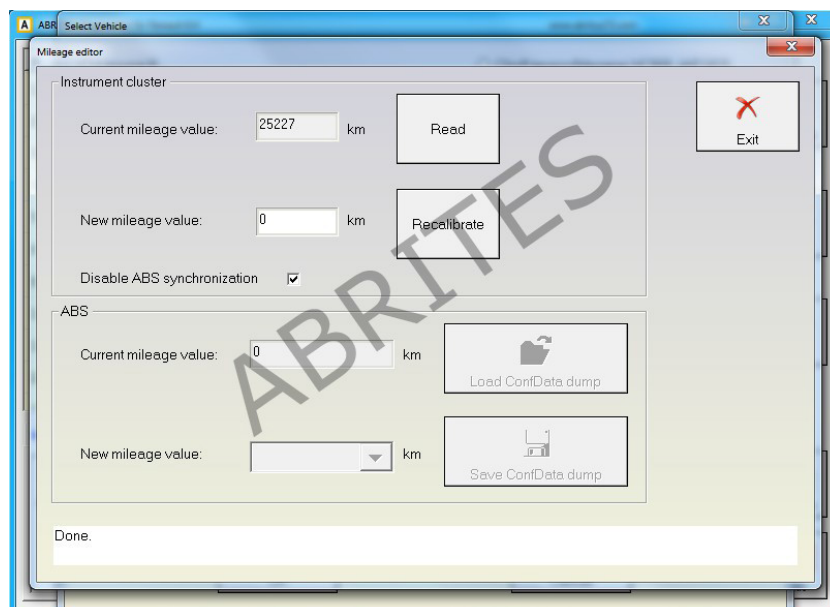

Instrument cluster Conf Data can be read, updated, saved to file and loaded via OBD:

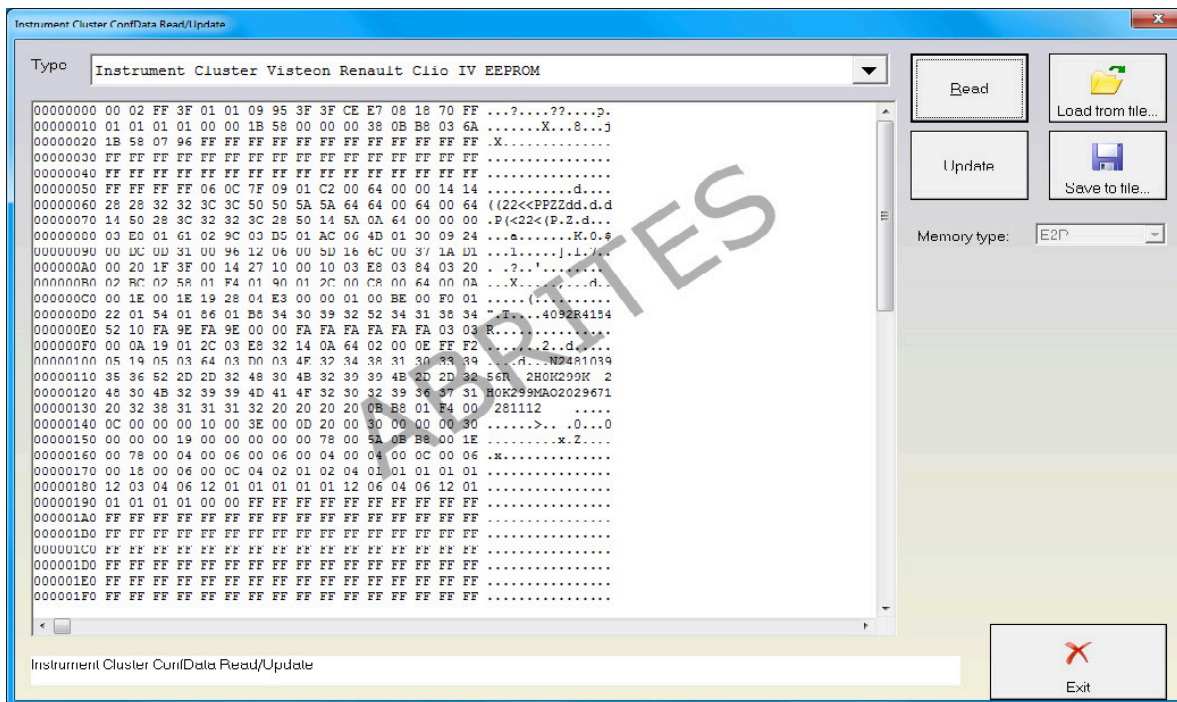

#### 4.7 ECU configuration data, flash and IMMO data reading and updating

When a situation requires for the ECU configuration data, flash and IMMO data to be read the Abrites diagnostics for Renault can assist. This option is focused on different ECUs within the Renault vehicle brand. Currently the support for the ECUs includes the following:

##### Reading and updating the EEPROM of the following ECUs:

- EDC15C3
- EDC15C13
- EDC17
- SIRIUS32
- SID301
- SIM32
- SAFIR/SAFIR2/SAFIR200
- IAW 6R.20
- IAW 6R.30 (reading only)

### Reading and updating the FLASH of the following ECUs:

- EDC15C3
- EDC15C13
- EDC17
- SIRIUS32
- SID301
- SIM32

### Clearing IMMO code data for the following ECUs:

- EDC15C3
- EDC15C13
- EDC17
- SIRIUS32
- SID301
- SIM32
- IAW 6R.30

You can operate with all these ECUs on a desk using the following adapter OBDII to DB9 Male:

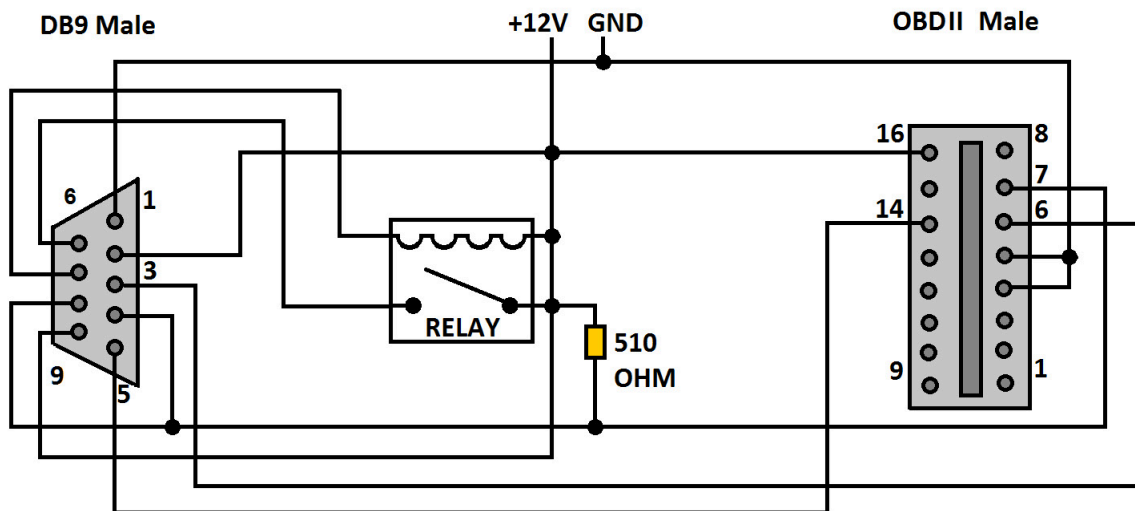

## 4.7.1 EDC15C3

For this ECU the type of MCU is SAK-C167CS-LM, the external flash is AM29F400BT with size of 512 KB. The configuration data is stored in EEPROM 95P08 with size of 1 KB.

Use the following pinout to DB9 Female connector:

DB9 F Pin	ECU Connector	ECU Pin
1	B	M4
2	B	E3
3		
4	A	C3
5		
6	B	M3
7	B	D4
8	A	D3
9		

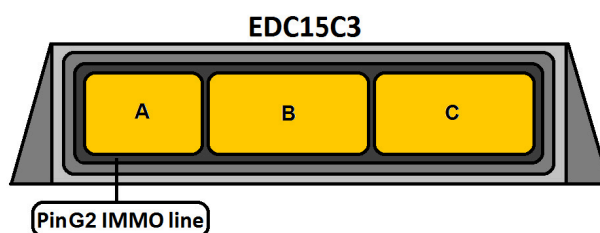

After clearing the IMMO code, the ECU will perform self-learning with the first ignition cycle when a valid signal from immobilizer is present. Note that you need a valid signal from immobilizer system to start the engine!

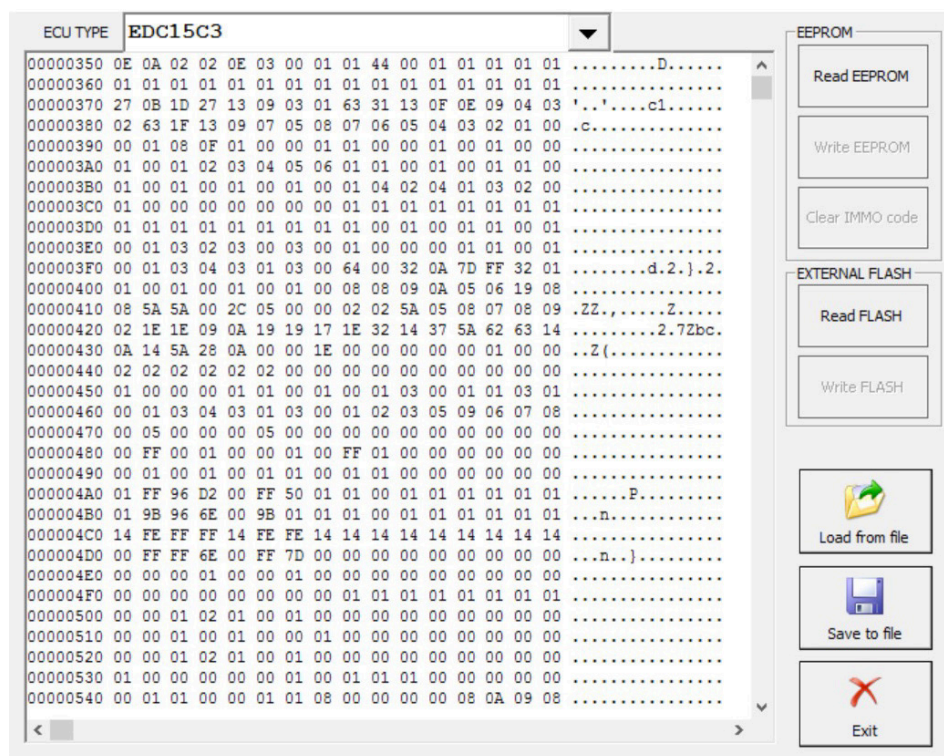

### 4.7.2 EDC15C13

Please bare in mind that the EDC15C13 box looks very similar to the EDC16 boxes. Please make sure that you check the BOSCH number to be 100% sure what ECU you have. The MCU type is SAK-C167CS-LM. The external flash is AM29F400BT with size of 512 KB. The configuration data could be stored either on 5P08 or 35P08 EEPROM with size is 1KB.

You can read and write the configuration data and the full flash using the appropriate buttons.

After clearing the IMMO code, the ECU will perform self-learning with the first ignition cycle when a valid signal from immobilizer is present. Note that you need a valid signal from immobilizer system to start the engine!

Use the following pinout to DB9 Female connector:

DB9 Female Pin	ECU Connector	ECU Pin
1	B	M4
2	B	A1
3		
4	C	F2
5		
6	B	M3
7	B	F1
8		
9		

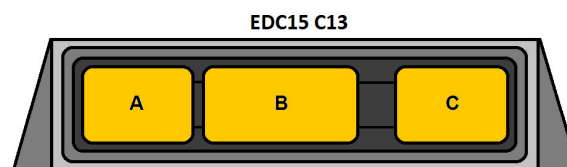

### 4.7.3 SID301

The SID301 ECU has a MPC561 MCU type and the external flash type is AM29BDD160GB with size of 2 MB. The configuration data is stored on 95320 EEPROM with 4KB. After clearing the IMMO code, the ECU will perform self-learning with the first ignition cycle when a valid signal from immobilizer is present. Note that you need a valid signal from immobilizer system to start the engine!

Use the following pinout to DB9 Female connector:

DB9 Female Pin	ECU Connector	ECU Pin
1	C	H4
2		
3	C	A4
4		
5	C	A3
6		
7		
8		
9	C	D1
9	B	G4

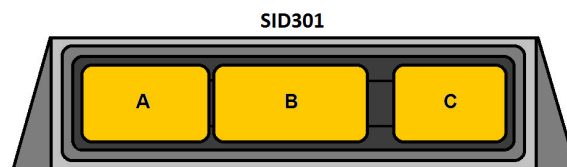



#### 4.7.4 SIRIUS 32

For these ECUs we have two options for the type of MCU: SAK-C167SR-LM an SAK-C167CR-LM.  
The external flash is AM29F200BB, 256KB in size.

After clearing the IMMO code, the ECU will perform self-learning with the first ignition cycle when a valid signal from immobilizer is present. Note that you need a valid signal from immobilizer system to start the engine!

Use the following pinout to DB9 Female connector:

DB9 Female Pin	ECU Connector	ECU Pin
1	B	28
2	B	29
3		
4	B	56
5		
6	A	66
7	A	39
8	B	26
9	B	30

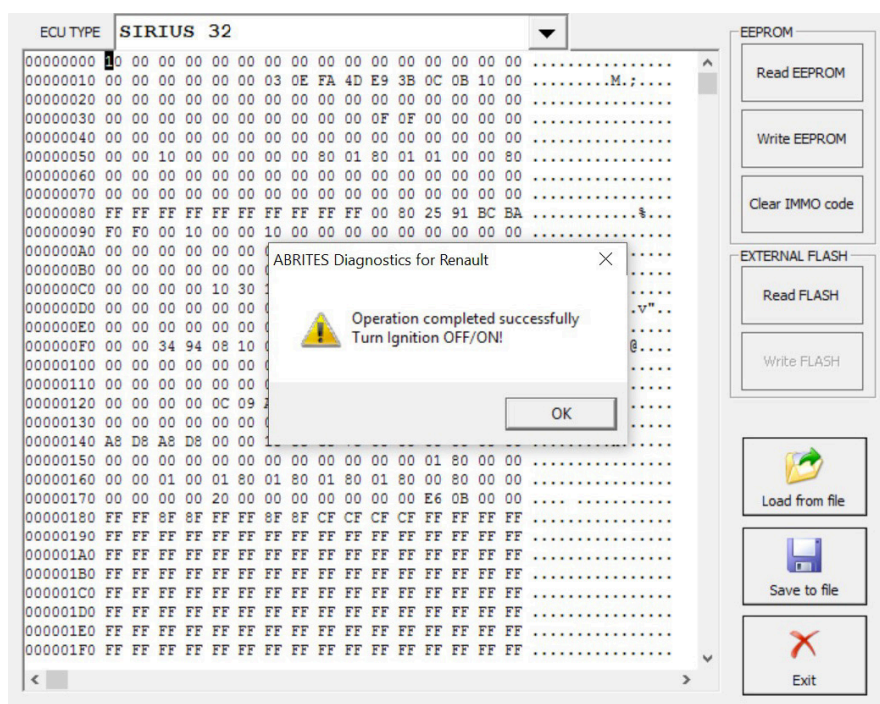
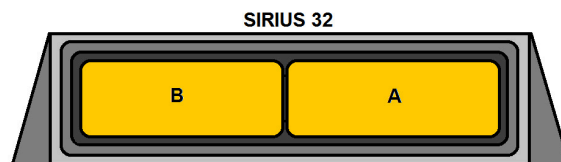



#### 4.7.5 SAFIR/SAFIR2/SFR200 using 35 or 55 pin connector

The Sagem Safir/Safir2 and Magneti Marelli SFR200 ECUs have a TMS374 internal MCU. The configuration data is 256 KB. For these ECUs you can read the configuration data of the TMS374, you can clear the IMMO code and the car can run with the cleared code if the immobilizer line is disconnected from the ECU. In this case the Immobilizer line for the 35 pin connector is pin 30 and for 55 pin connector – it is pin 37.

After clearing the IMMO code, the ECU will perform self-learning with the first ignition cycle when a valid signal from immobilizer is present. Note that you need a valid signal from immobilizer system to start the engine!

Use the following pinout to DB9 Female connector for 35 pin version:

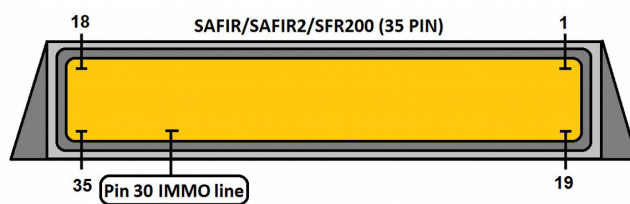

DB9 Female Pin	ECU Pin
1	4.34
2	
3	
4	9
5	
6	
7	20
8	10
9	18

Use the following pinout to DB9 Female connector for 55 pin version:

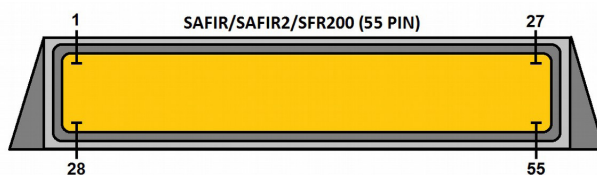

DB9 Female Pin	ECU Pin
1	2.18
2	
3	
4	11
5	
6	
7	48
8	38
9	1



#### 4.7.6 SIM32

The Siemens SIM32 has a HD64F7055 MCU with 512KB FLASH. The configuration data is 2KB stored in 95160 EEPROM.

After clearing the IMMO code, the ECU will perform self-learning with the first ignition cycle when a valid signal from immobilizer is present. Note that you need a valid signal from immobilizer system to start the engine!

Use the following pinout to DB9 Female connector:

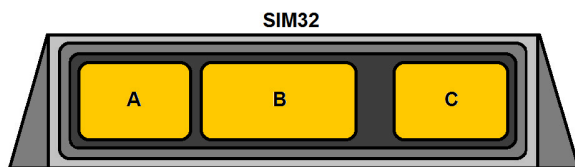

DB9 Female Pin	ECU Connector	ECU Pin
1	C	H4
2	C	D1
3	C	A4
4	C	B4
5	C	A3
6	B	J1
7		
8	B	G1
9	A	G1

#### 4.7.7 IAW 6R.20/6R.30

The Magneti Marelli IAW 6R.20/6R.30 ECUs have a TMS370 MCU. The configuration data is 256 bytes inside the MCU. For 6R.20 you can read/write the configuration data while on 6R.30 you can read the configuration data and clear the IMMO code.

The car can run with the cleared code if the immobilizer line (pin 25) is disconnected from ECU.

After clearing the IMMO code, the ECU will perform self-learning with the first ignition cycle when a valid signal from immobilizer is present. Note that you need a valid signal from immobilizer system to start the engine!

Use the following pinout to DB9 Female connector:

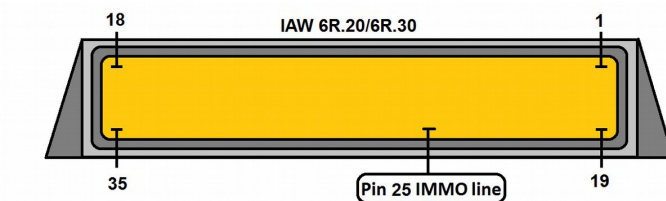

DB9 Female Pin	ECU Pin
1	17.34
2	
3	
4	15
5	
6	
7	23
8	10
9	35

### 4.7.8 EDC17 Boot mode reading

The EDC 17 ECUs can be read by boot mode. You can read the Flash and configuration data.

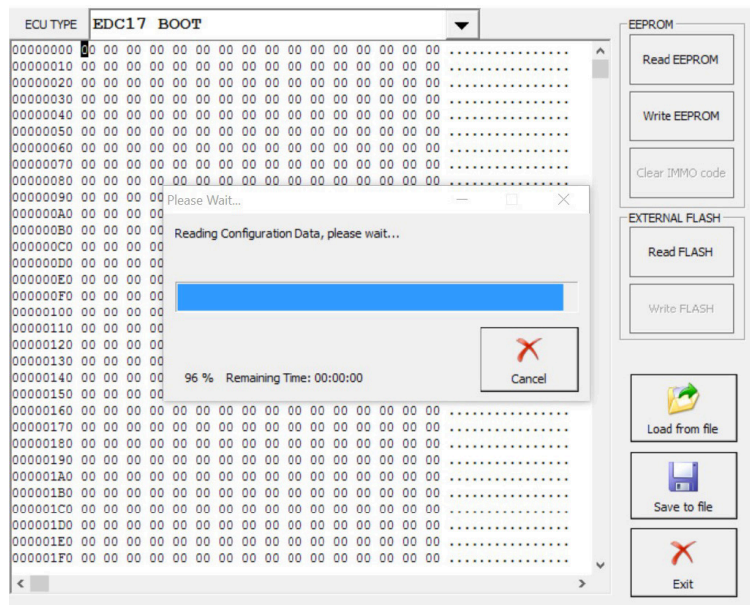

They can also be saved to files and used later. They can be transferred and updated to other ECUs. Please note that the pinout connections are similar to the ones in the Abrates diagnostics for VAG EDC17 connections.

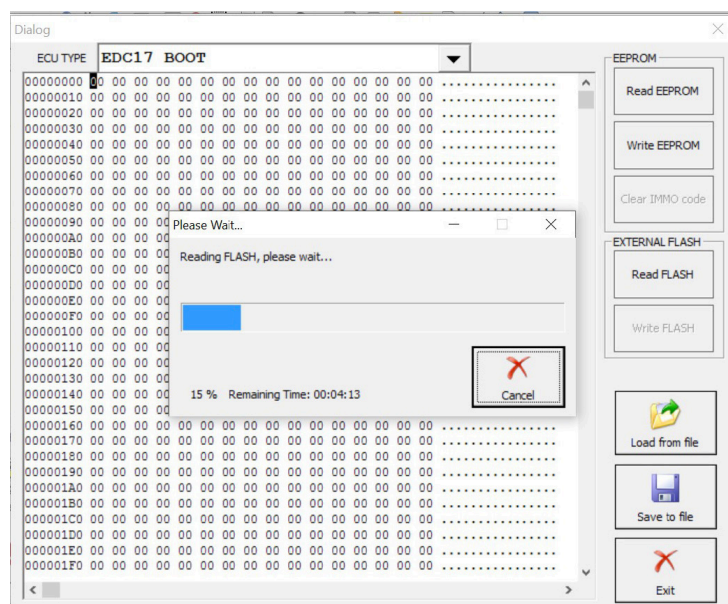

## 4.8 EDC 17 Specific functions

There are some EDC17 specific diagnostic functions available - injector coding and DPF regeneration.

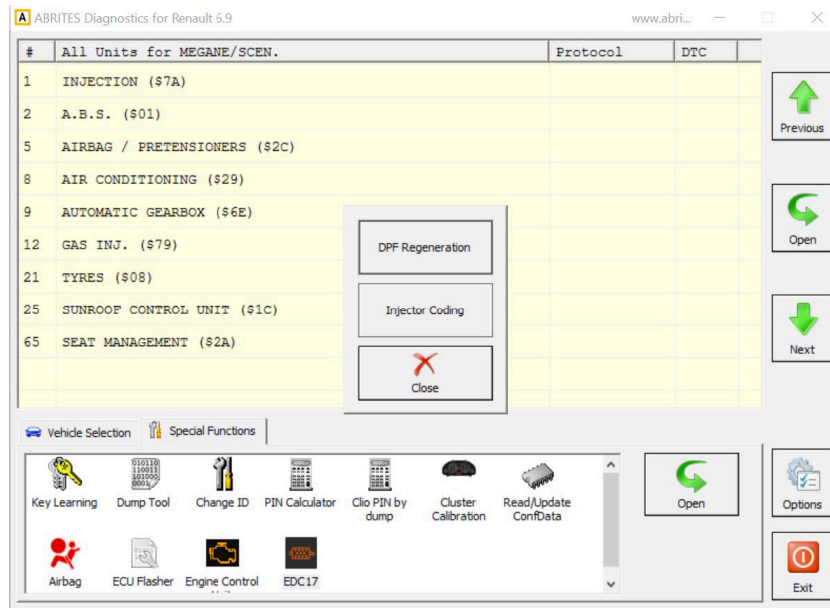

The injector coding function will allow you to read the injector codes, and write the new ones when an injector has been replaced for example. Take additional attention when writing the new values - there is a checksum inside the code and ECU will refuse to accept invalid codes.

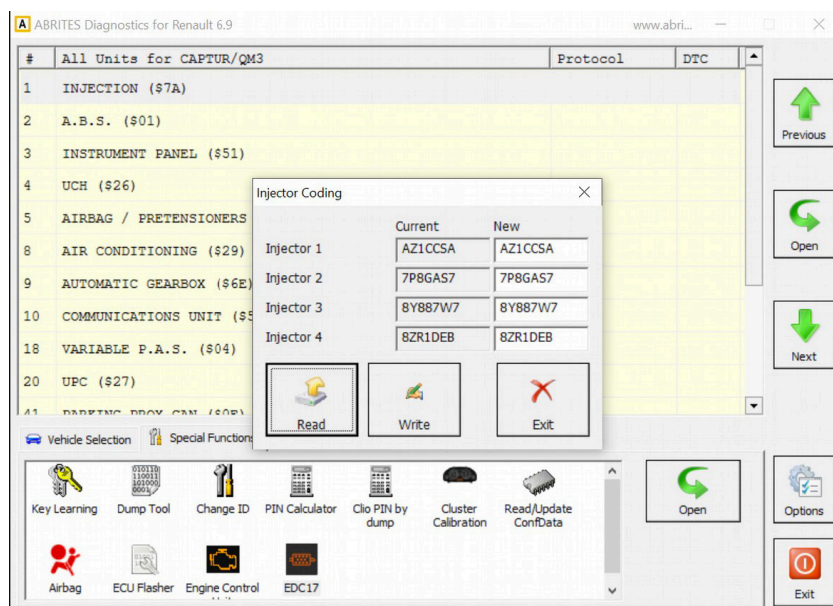

Before starting the procedure, please be sure that the vehicle is placed on non-flammable surface away from public places! It is recommended to observe the vehicle from a distance with a fire extinguisher on hand.

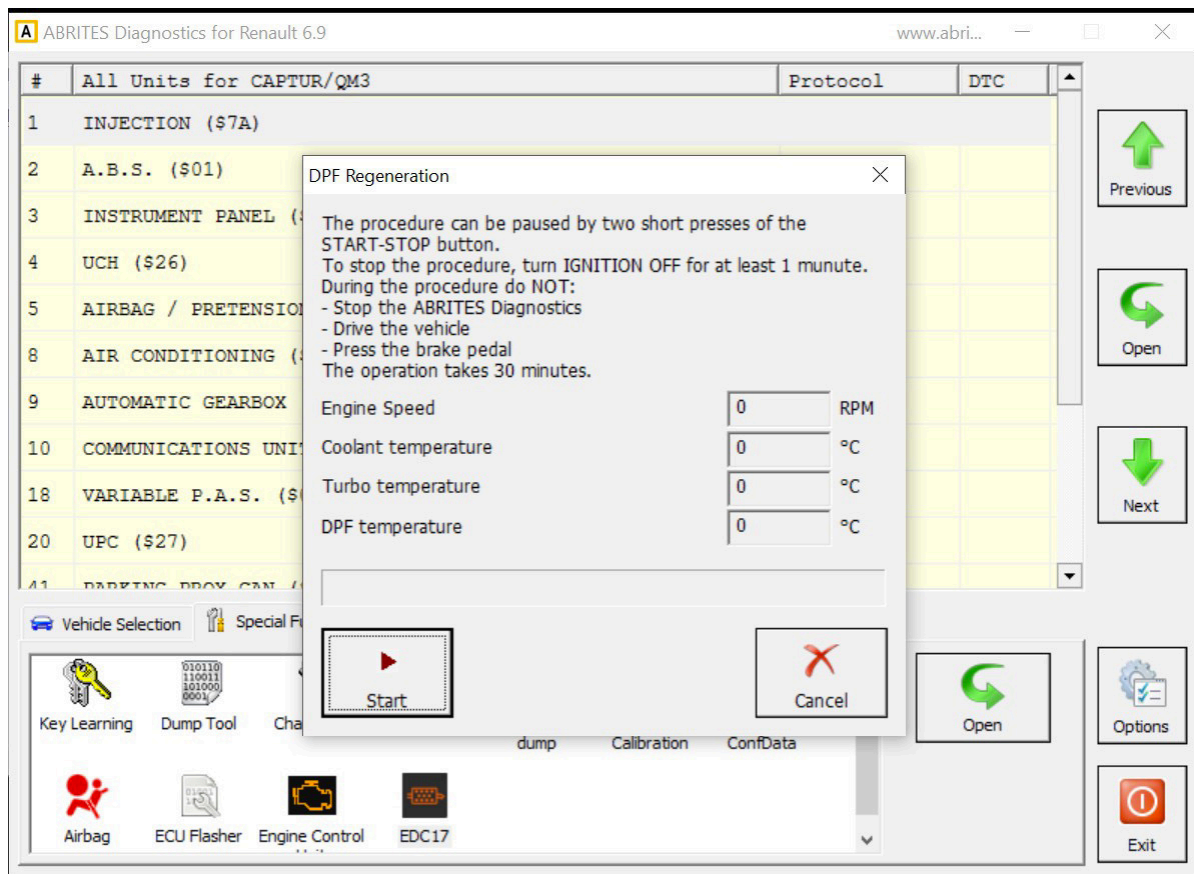



Reading the CLIO IV/ Captur handsfree module:

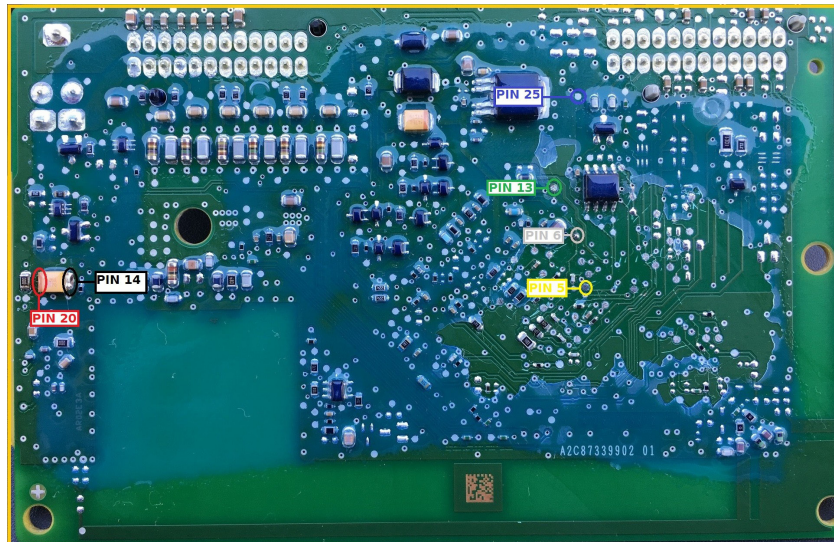

Renault Clío IV/ Captur handsfree connection for all keys lost procedure.  
In this case we provide a connection to a male DB25 connector.

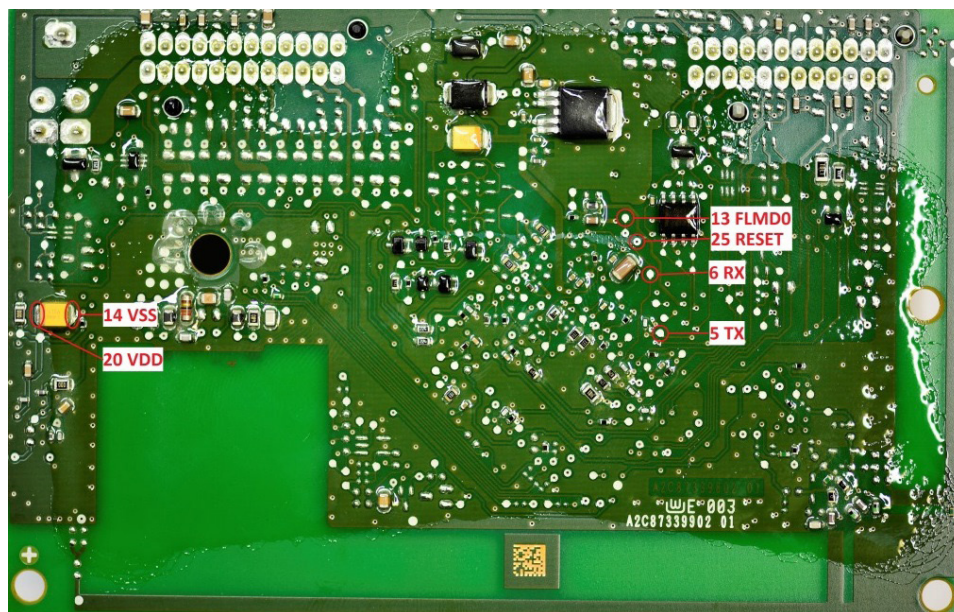

**NB!**

Please note that the Male DB25 must be connected to the ABPROG which must be connected to the AVDI. Then you can read the handsfree module.

## 4.9 Renewal

The Abrates Diagnostics for Renault/Dacia offers the new “Renew” Special Function. It will allow you to renew Airbags, UCH, EPS and ESL. The “Renew” Function can be located under the main Special Functions list:

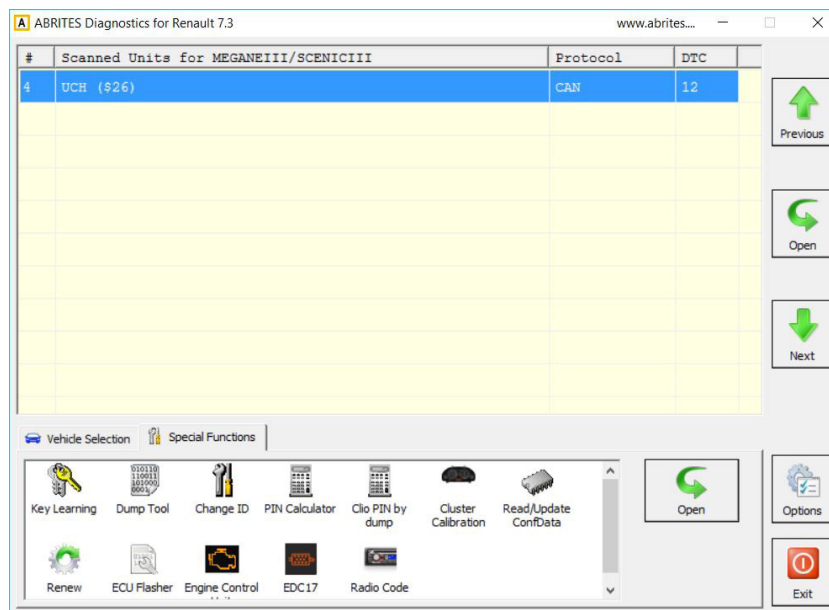

Once you open the “Renew” Special Function, a new Window will appear, letting you choose from four different options- Airbag, UCH, EPS and ESL:

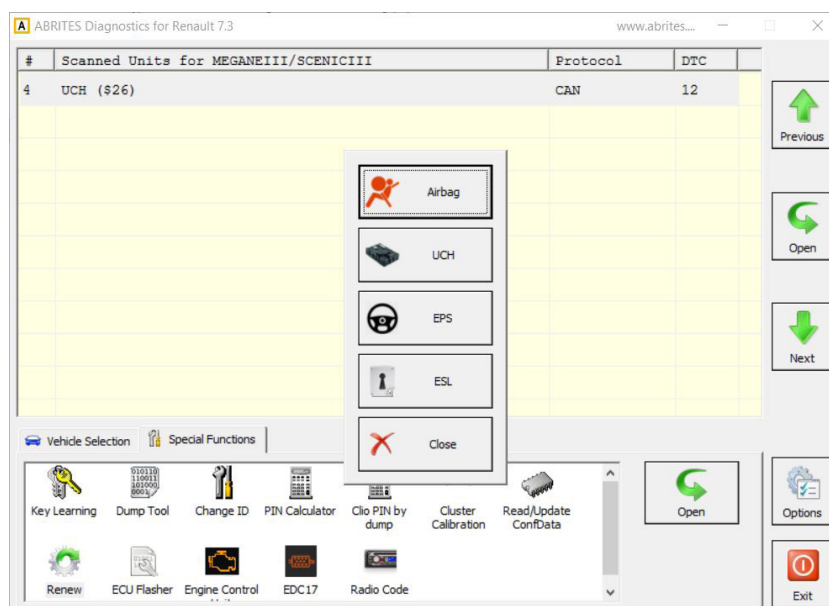



After choosing the desired renewal function, you will be prompted to select the ECU of the car.

### 1. Airbag

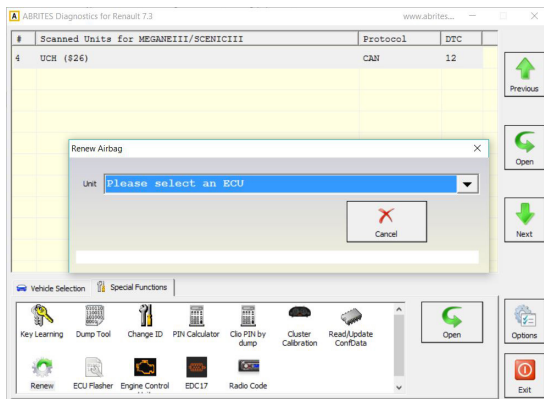

### 2. UCH

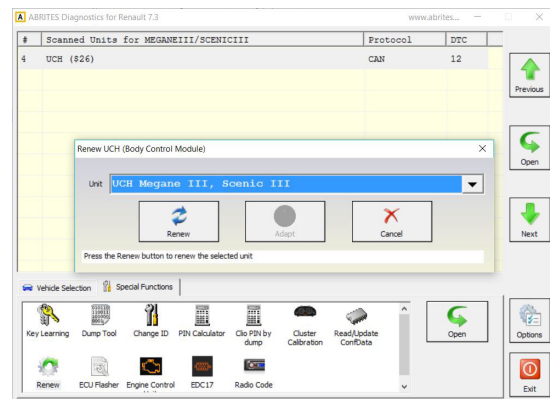

### 3. EPS

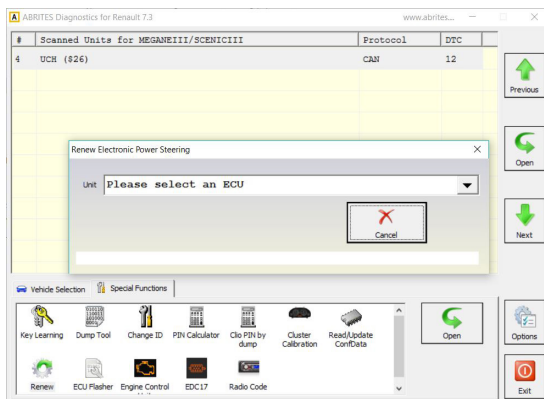

### 4. ESL

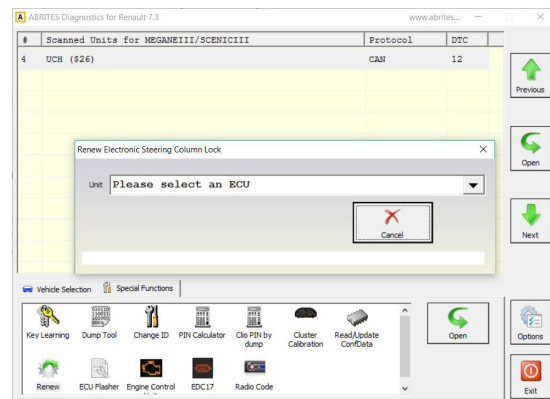

Renewing the UCH will offers more options, which should be taken into consideration. After you make the renewal, you can also adapt the UCH by entering new VIN to the unit and new PIN. To make the renewal, the next steps can be followed.

1. Open the UCH renewal and select an ECU

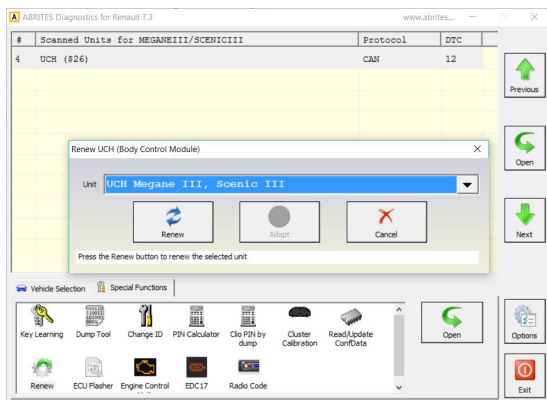

2. Confirm with "Yes" after the warning

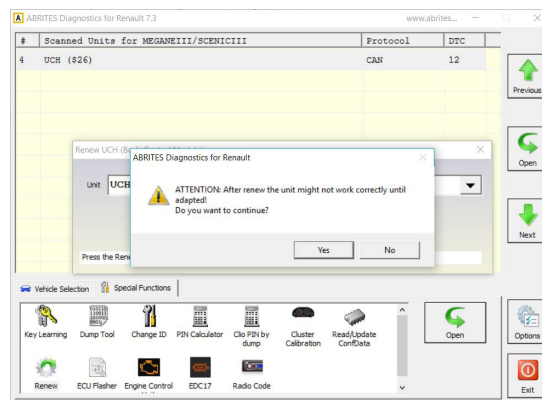

3. The unit is renewed now

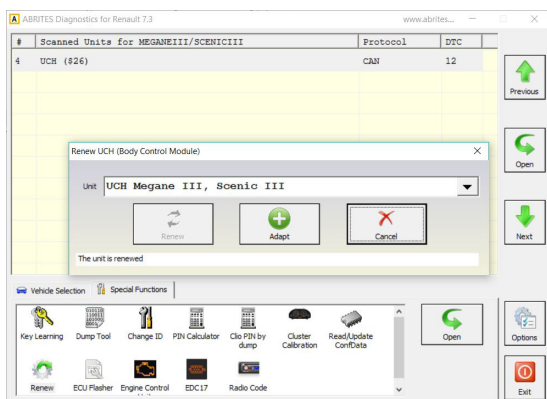

4. Make sure to have the original PIN code

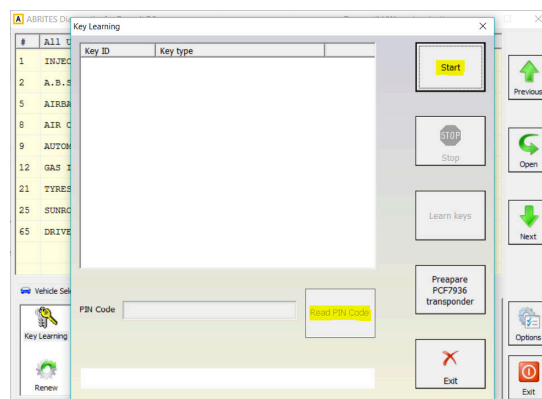

To adapt the new UCH module, simply click on "Adapt" and enter the new VIN:

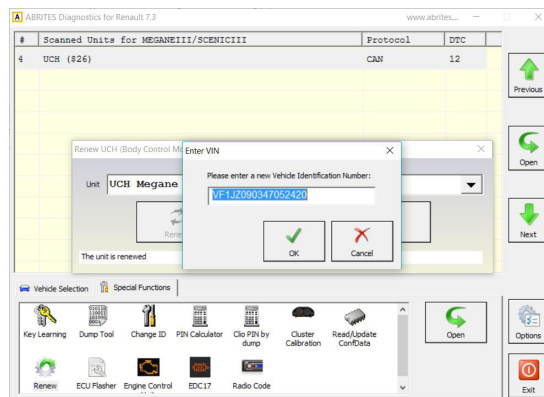

1. Remove the key card and switch ignition OFF

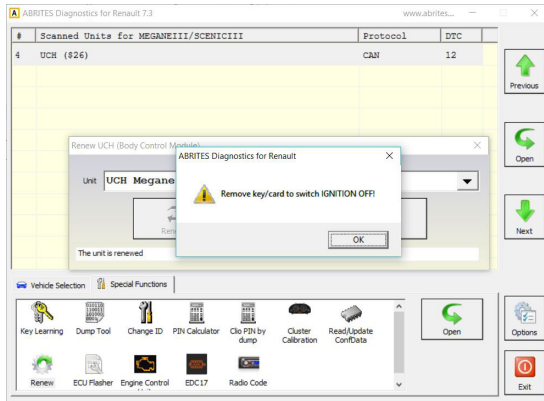

2. Enter the original PIN

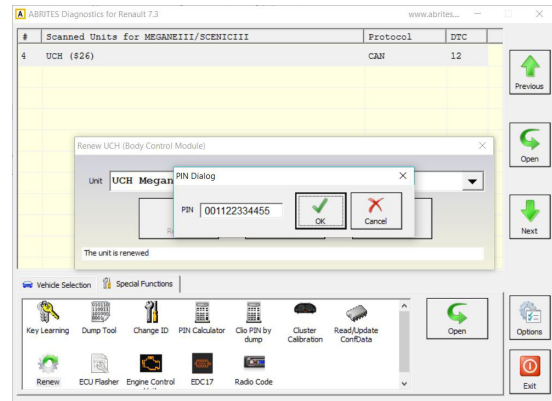

3. Insert the key card and switch Ignition ON

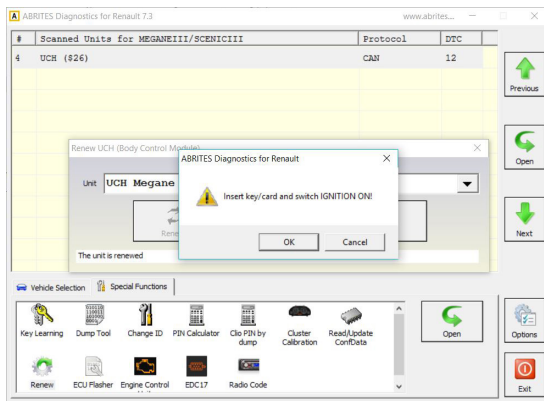

4. Turn the ignition to OFF/ON

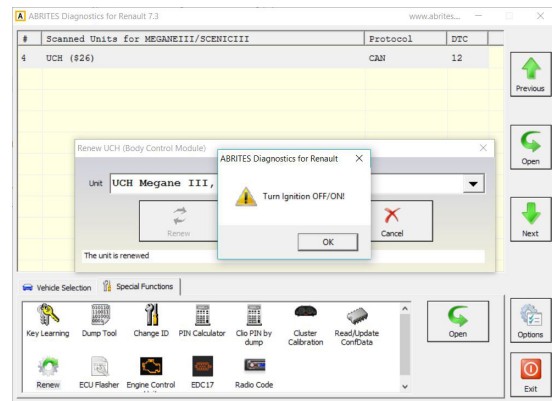

5. The operation has successfully completed and the new UCH is now adapted.

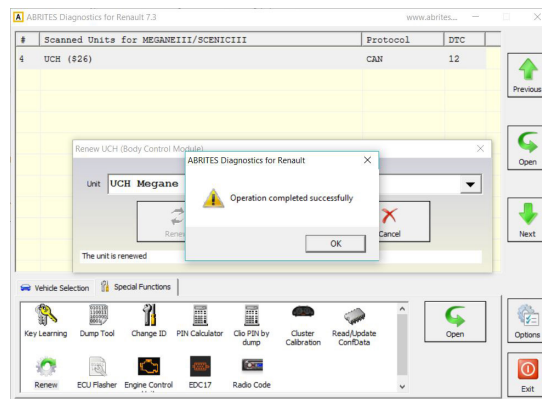

## 4.10 Radio Code

The Abrates Diagnostics for Renault 7.3 offers the “Radio Code” Special Function. It will allow you to adapt the radio if it was somehow reset.

You need to have the last 4 symbols from the ID, which can be obtained in three ways:

On the back side of the unit you can find the code.

In this case it is **Y135**:

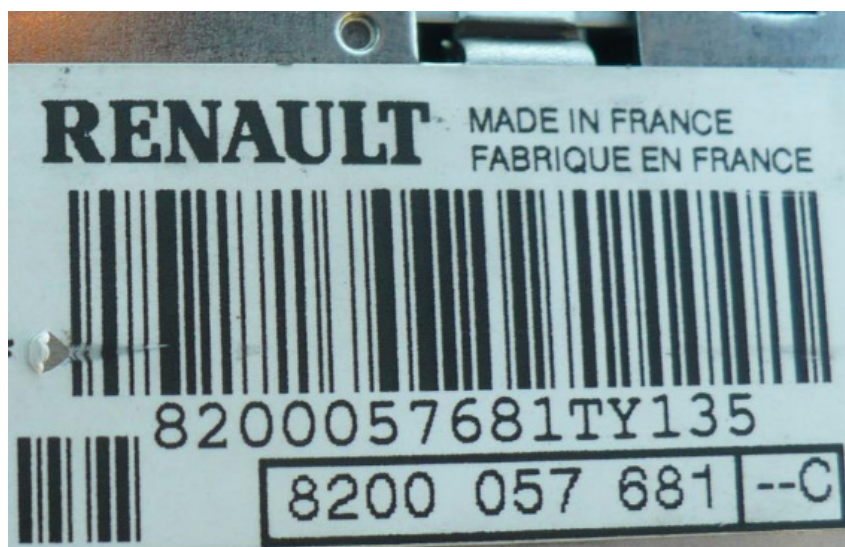

You can hold the radio buttons 1 and 6 for 3-4 seconds and the code should be automatically loaded on the radio display. The Twingo III car is an exception, where the code standard is different.

You can also click on the “Extended Identification of the radio when diagnosing the car and the code will be displayed as well.

Once you have the code, go to the “Radio Code” Special function and enter the code and calculate the radio code:

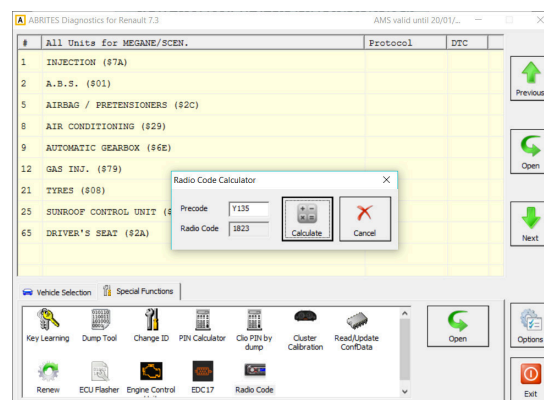
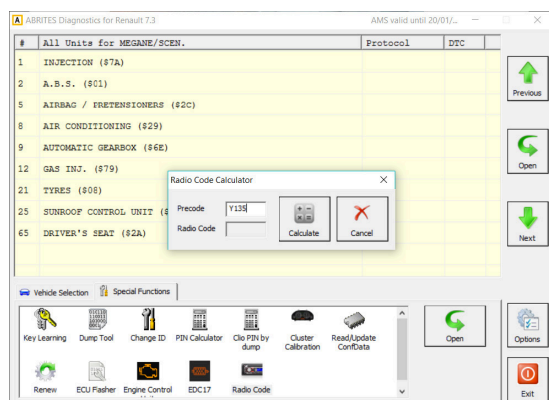

5. Connecting ECUs on bench using ZN051 Distribution Box

SAGEM SFR200

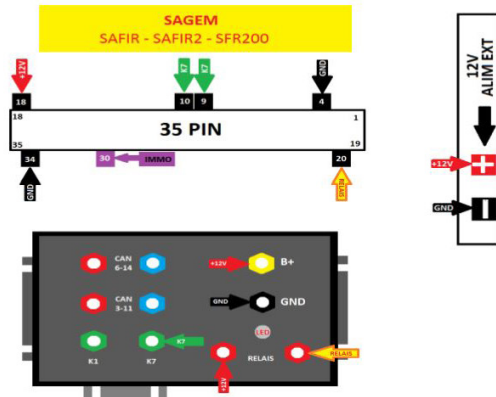

SIEMENS SIM32

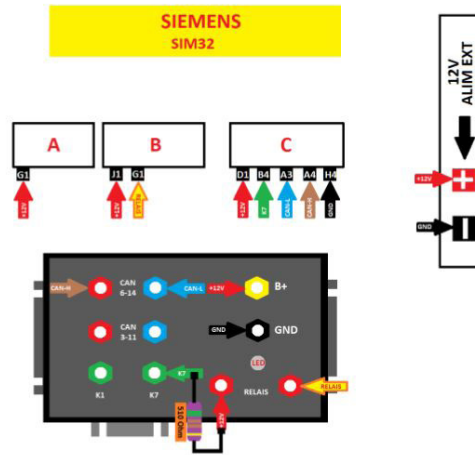

SAGEM SFR200

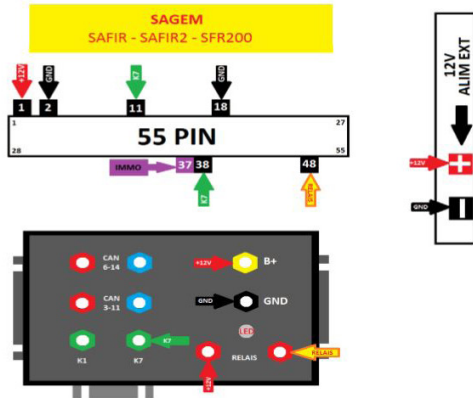

SIEMENS SIRIUS35

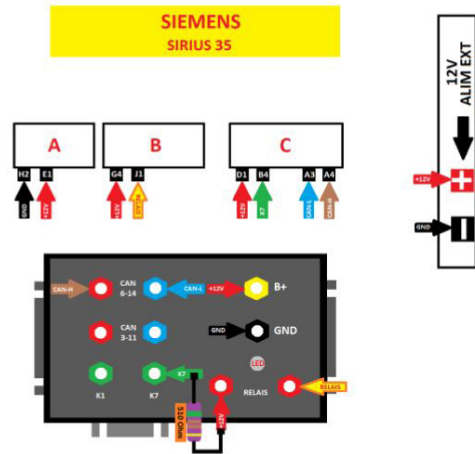

SIEMENS EMS3132

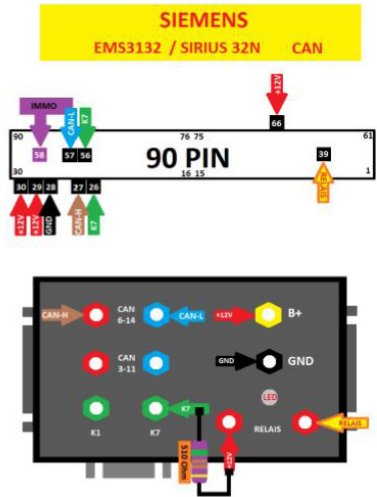

SIEMENS SIRIUS34 EMS3134

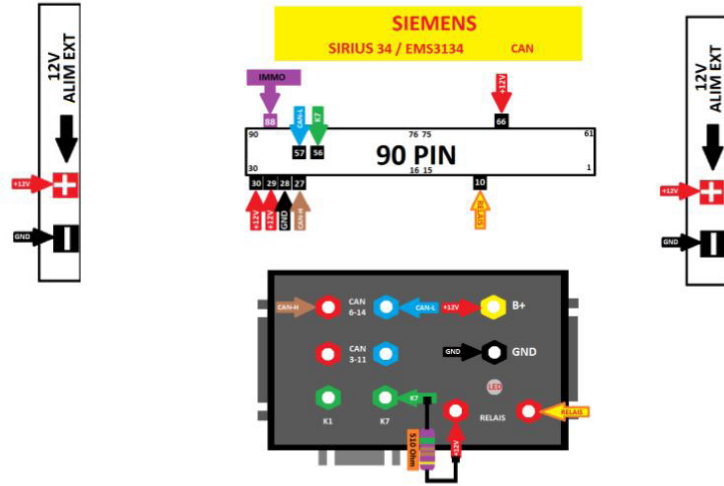

SIEMENS SIRIUS32N

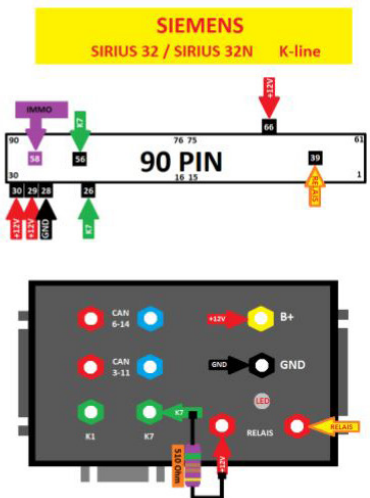

SIEMENS SIRIUS34 EMS3134

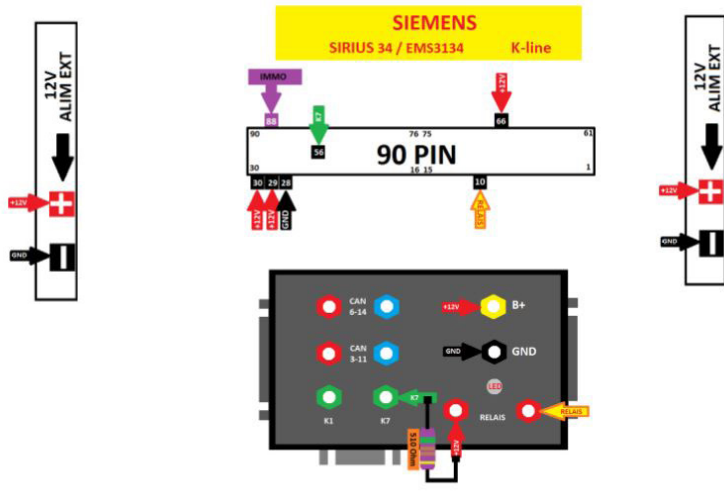

BOSCH EDC15C3

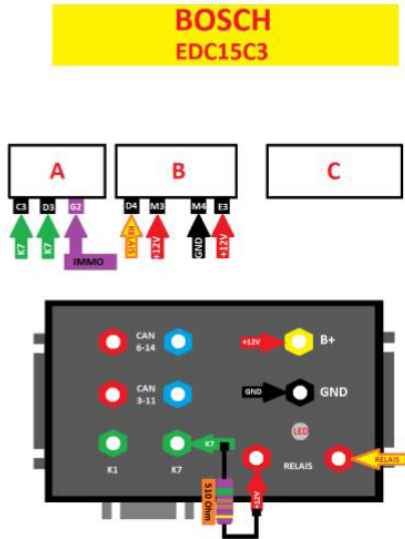

MM IAW 6R.20 6R.30

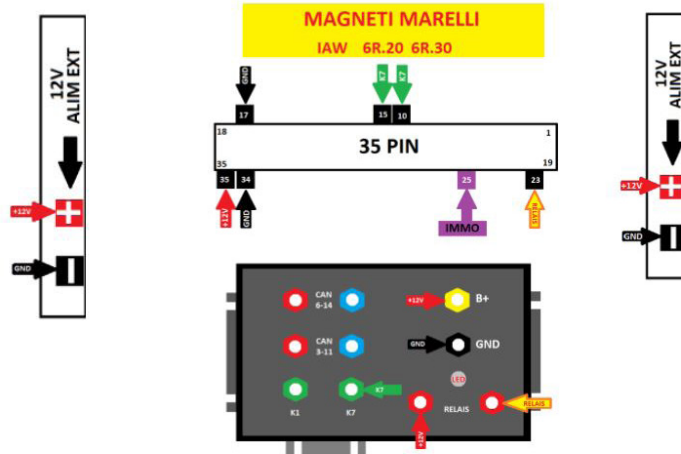

BOSCH EDC15 C13

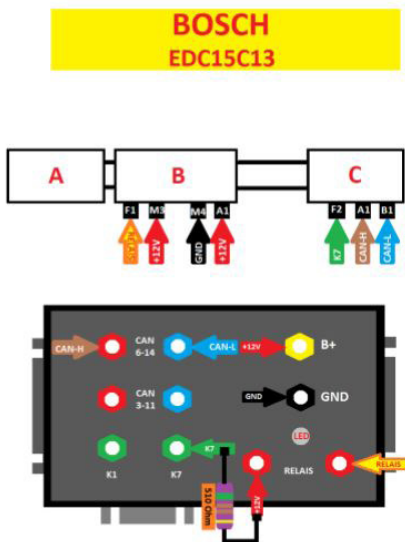

SIEMENS SID301

